

Electrical System

Electrical Distribution System



**Confederation of Indian Industry
CII – Godrej Green Business Centre, Hyderabad, India**

Transformer

- **Transformer**
 - **Heart of Electrical Distribution**
- **Category**
 - **Power Transformers**
 - **Distribution Transformers**



Types Of Transformers

❖ Transformer - Heart of Electrical Distribution

Distribution Transformer

- Normal Efficiency- 98% to 99%
- Iron loss is 10% to 15% of full load copper loss
- Fe loss take place throughout the day and Cu loss depends on load cycle
- Optimum efficiency occurs between 40% to 60% of loading

Power Transformer

- Normal Efficiency- 99% to 99.5%
- Iron losses is 20% to 25% of full load copper losses
- Cu and Fe loss take place through out the day
- Optimum efficiency occurs between 60% to 80% of loading

Transformer Efficiency

❖ Optimum efficiency

occurs at

- ▣ 50% load
- ▣ 75% load
- ▣ 100% load

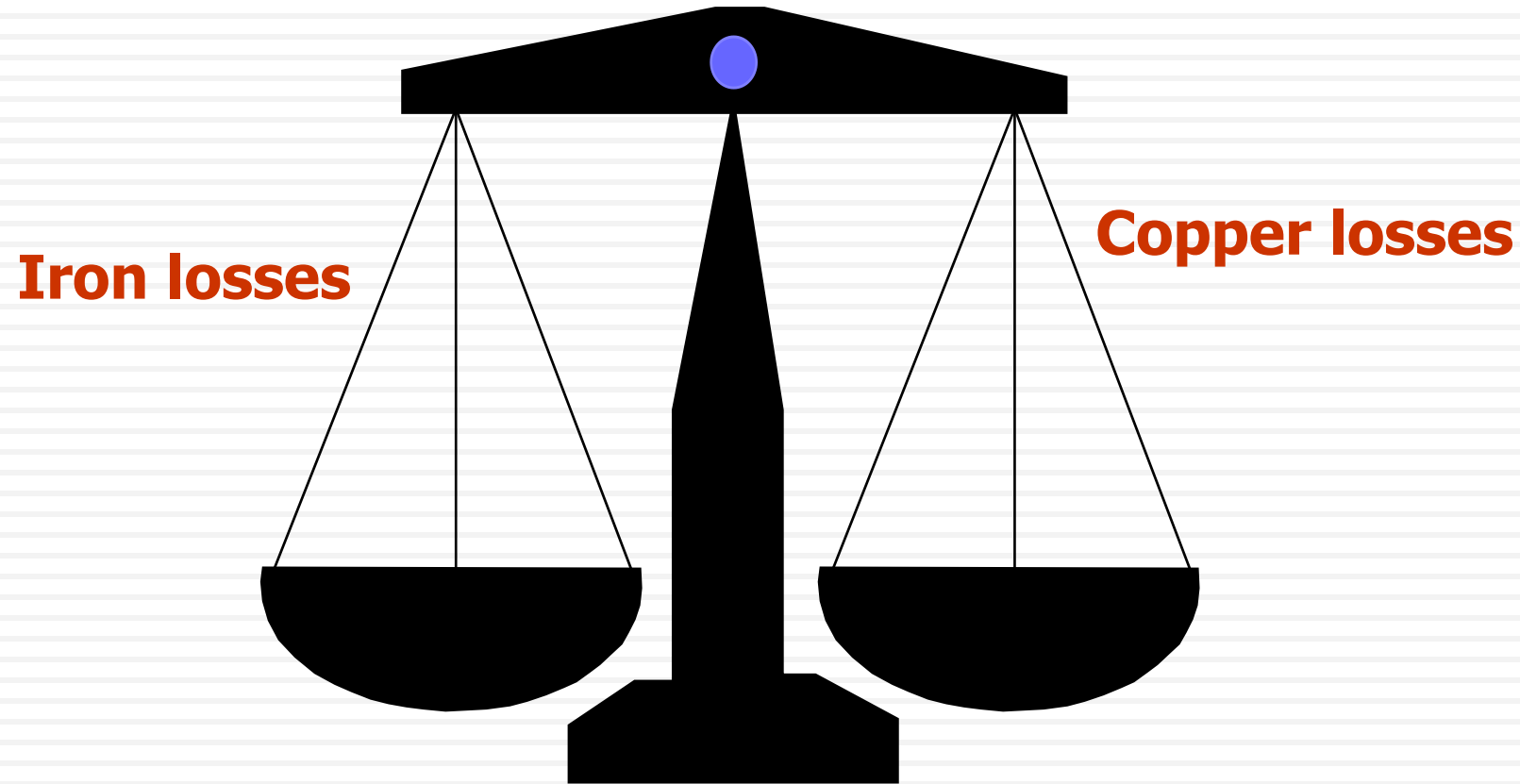

Case Study 1 – Parallel Operation of Transformer

❖ Background

▣ Capacity of transformer 2000

KVA

▣ Load on the transformer is 80%

▣ Iron loss = 3 kW

▣ F L Copper loss = 20 kW

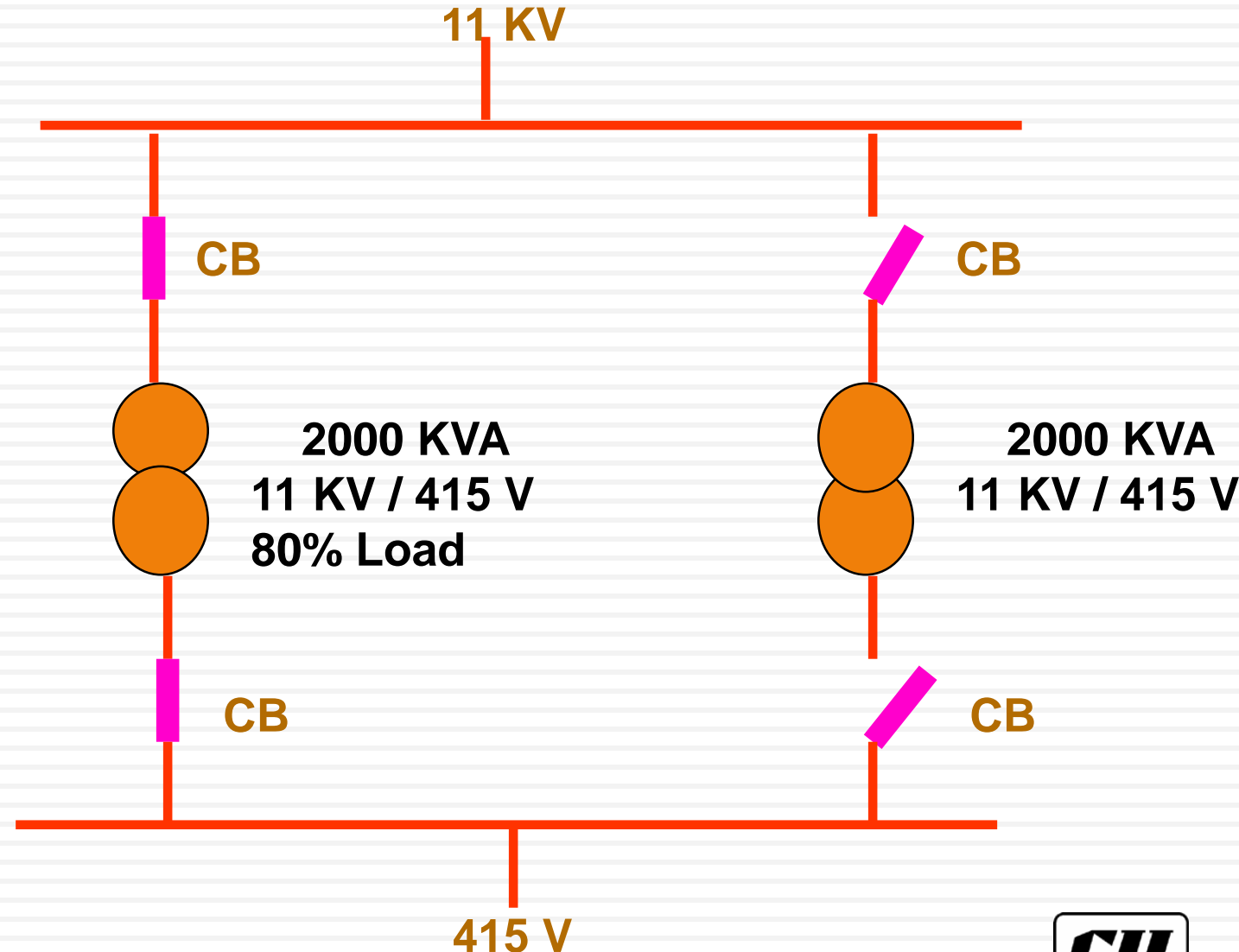

Case Study 1 – Parallel Operation of Transformer

❖ Loss calculation

- ❑ One transformer in operation

$$(3) + 20 \times (0.8)^2 = 15.8 \text{ kW}$$

- ❑ Both transformers are in operation

$$[(3) + 20 \times (0.4)^2] \times 2 = 12.4 \text{ kW}$$

- ❖ Plant operated both transformers in parallel

Annual Savings

: Rs.1.10 lakhs

Investment

: NIL

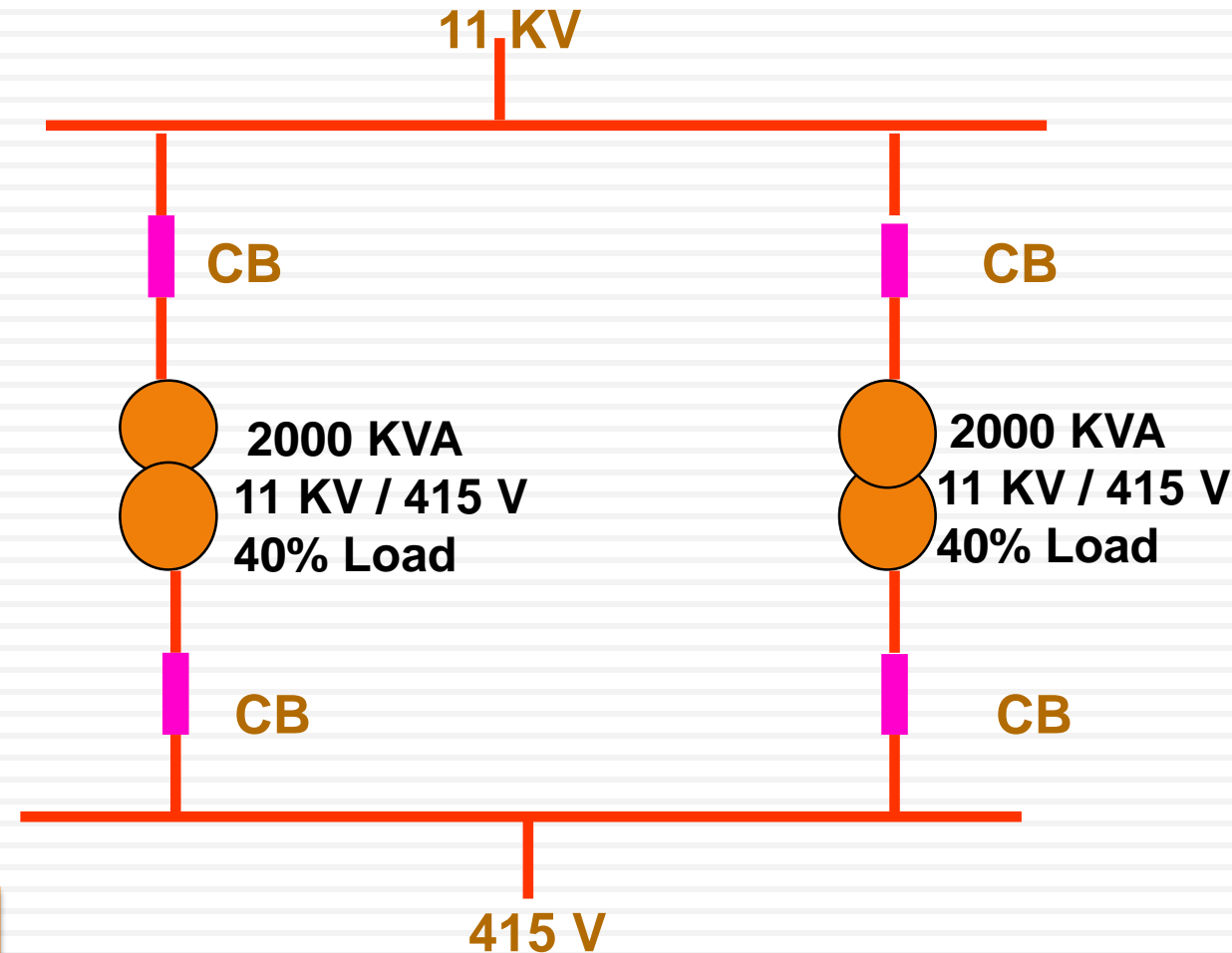

Case Study II – Isolate one transformer in Main Substation

❖ Background

- ❑ Two Transformers (12.5MVA) are operated parallel
- ❑ Actual total effective load is 6 MVA
- ❑ % load to the individual transformers is 24%

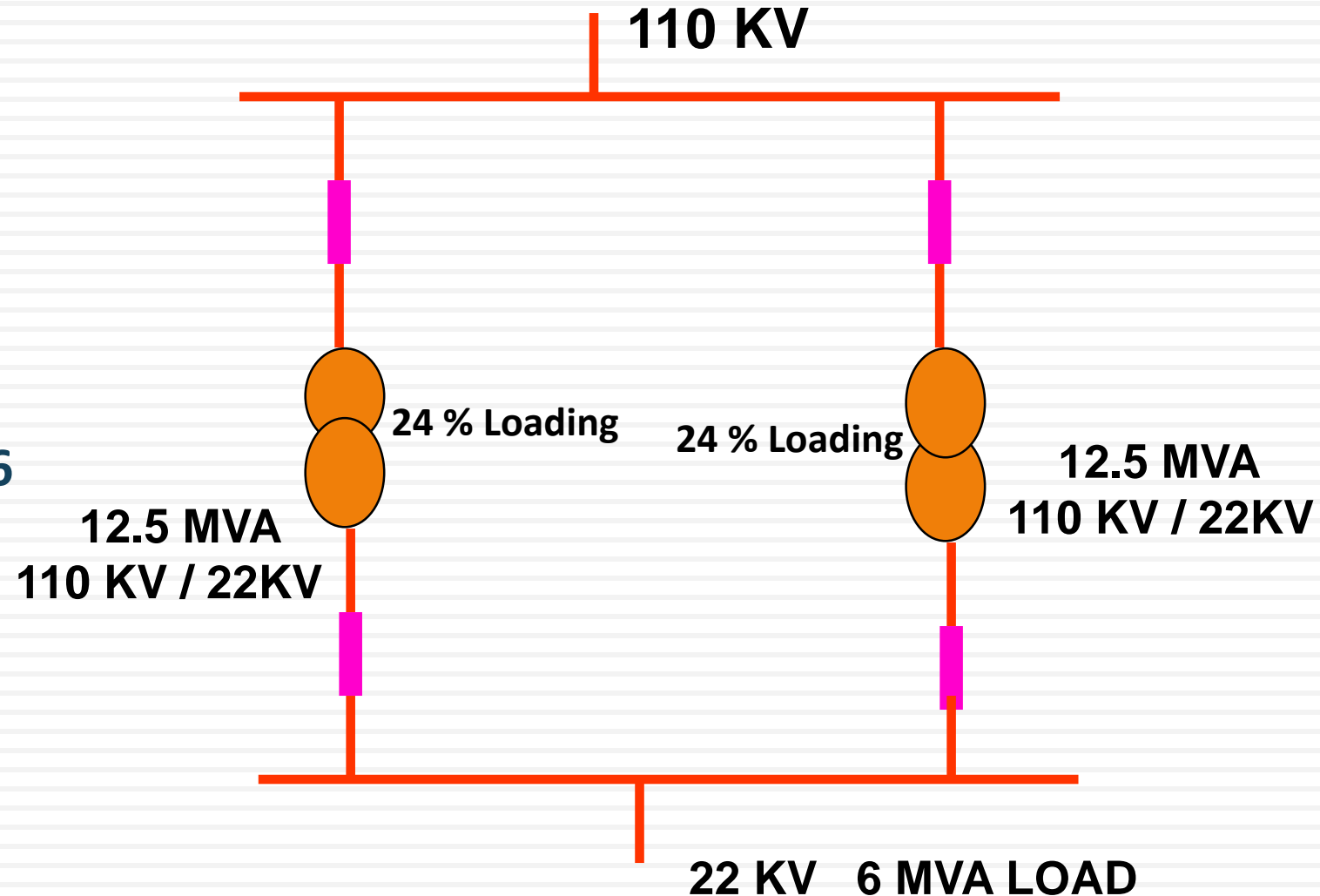

Case Study II – Isolate one transformer in Main Substation

❖ Loss calculation

- Both transformers are in operation

$$[(25) + 72 \times (0.24)^2] \times 2 = 58.2 \text{ kW}$$

- One transformer operation

$$(25) + 72 \times (0.48)^2 = 41.5 \text{ kW}$$

❖ Plant Isolated one transformer

Annual Savings	: Rs. 5.10 lakhs
Investment	: NIL

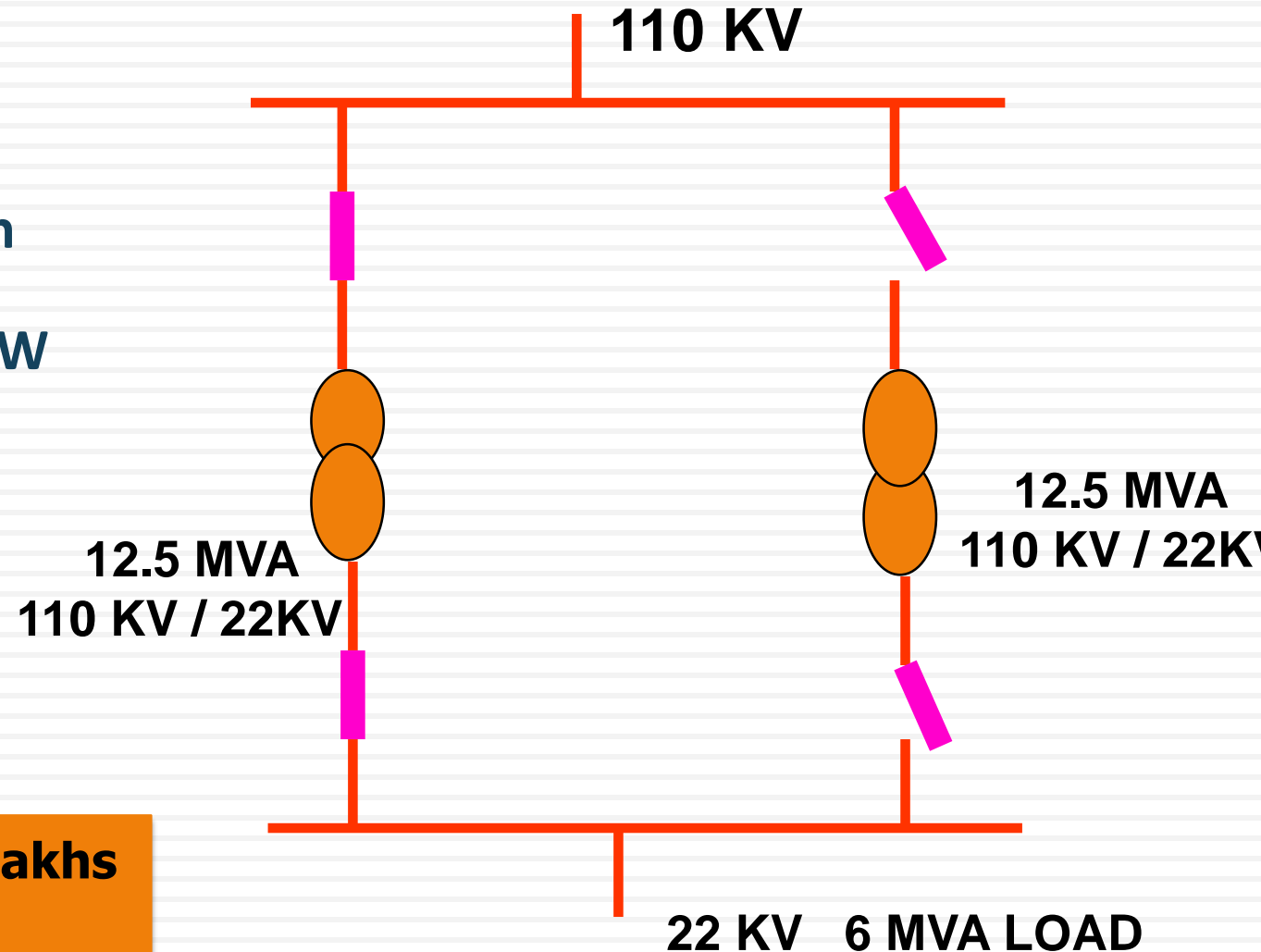

Case Study III- Idle Charging of Transformer primary

❖ Idle transformer consumes power for its inherent magnetization losses

▣ No load loss = 3 kW

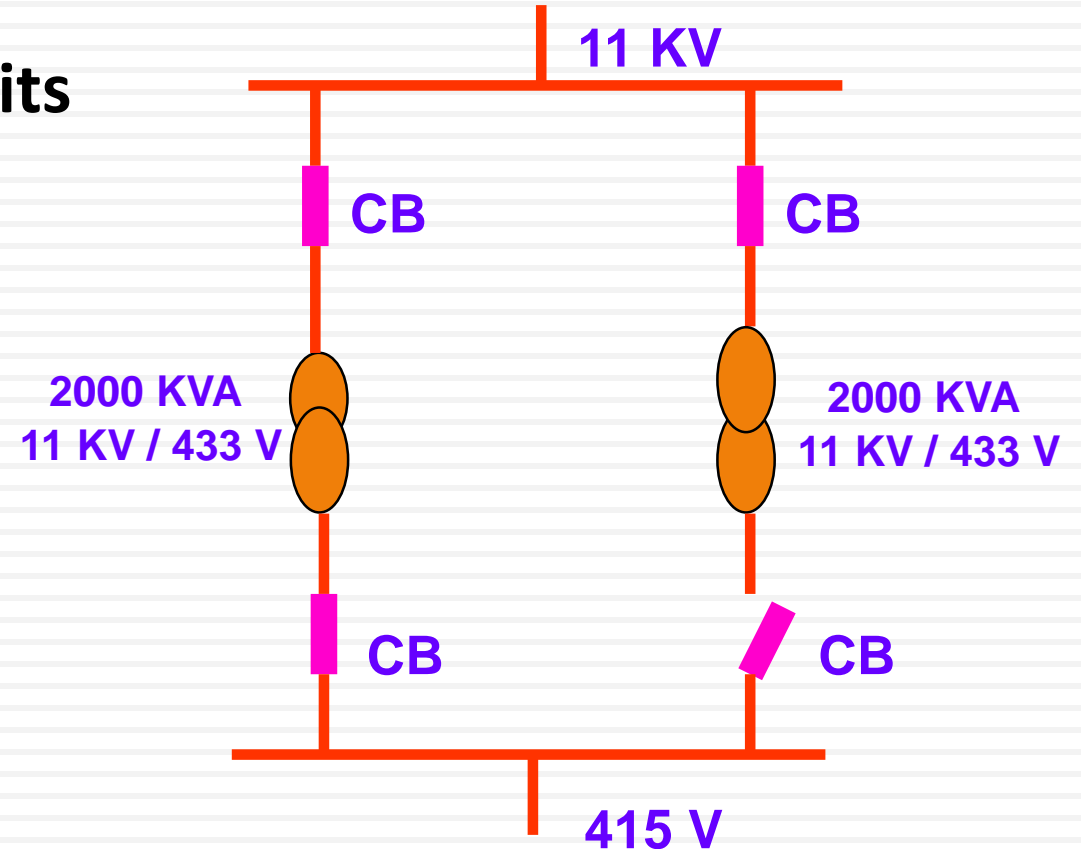

Case Study III- Idle Charging of Transformer primary

- ❖ Isolate Primary Of The Idle Transformer
- ❖ Saving = 3 kW

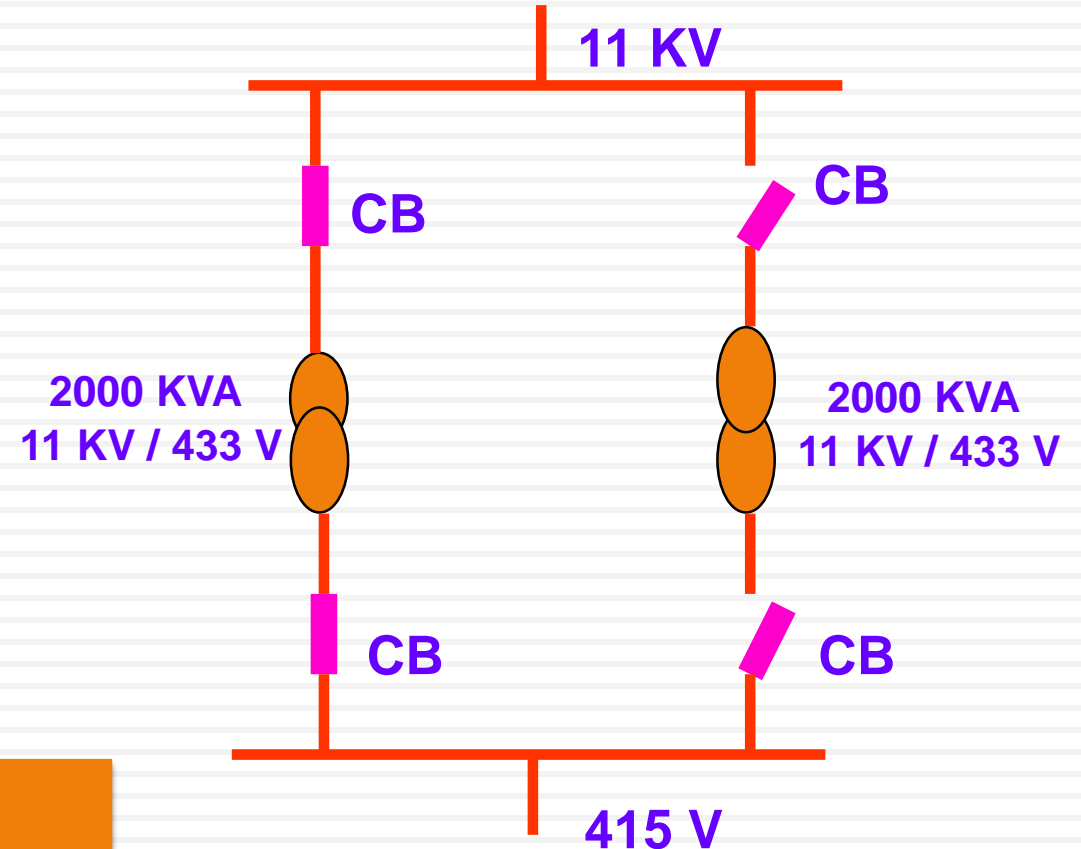

Annual Savings	: Rs 1 Lakh
Investment	: NIL

Energy Efficient transformer

- Core of the transformer is made of amorphous material
- Electrical resistivity of amorphous material is 2-3 times higher than silicon steel
- 70-80 % less core losses than normal transformers under linear loads
 - ▣ More savings under non linear loads

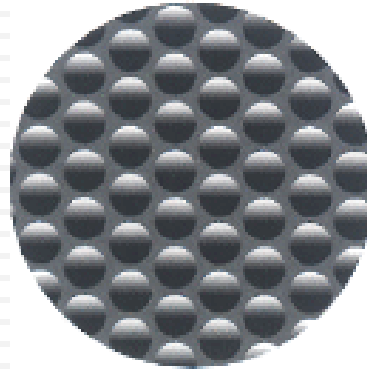

- Crystalline structures have hard directions for magnetization
- Requires grain orientation processing for best properties

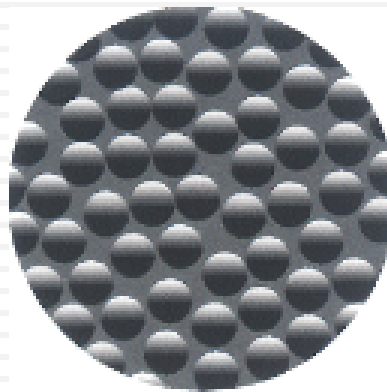

- In Amorphous random Arrangement of atoms offers High electrical resistance for eddy current.
- Easy to magnetize and Demagnetize

Transformer Losses & Efficiency

Transformer Rating	Core Loss (W)		Loss Reduction %
	Silicon Steel <i>In Service</i>	Amorphous Metal <i>Best</i>	
50 kVA, 1-Phase	210	105	75 to 80%
300 kVA, 3-Phase	1000	500	

Rating (kVA)	No Load Loss (W)		Efficiency (%)	
	Amorphous	CRGO	Amorphous	CRGO
250	180	570	98.7	98.2
500	250	900	99	98.53
630	200	1000	99.1	98.54
730	365	1250	99.2	98.65
1000	450	1500	99.2	98.68

Transformer efficiency

TRANSFORMER EFFICIENCY

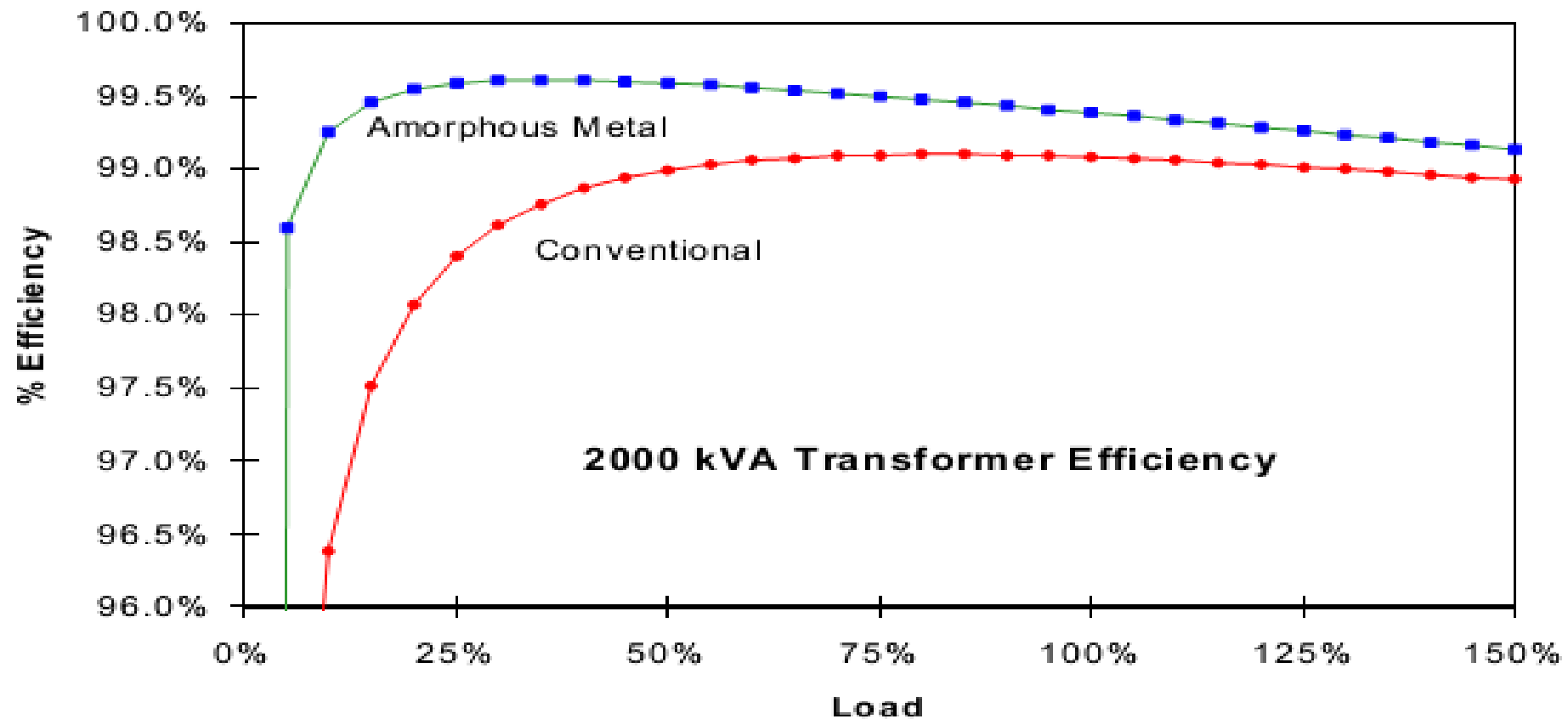

Example – Harmonics Losses (250 KVA)

Harmonic Content (THD~25%)

Harmonics	1	3	5	7	9	11	13	15	17
Content (%)	100	1	20	10	1	9	6	1	5

Transformer Losses without Harmonic Distortion

Loss (W)	Amorphous Metal	Silicon Steel
Hysteresis	99	155
Eddy Current	33	311
Total Core Loss	132	466
Coil Loss	966	1,084
Loading Level (%)	55	58
Total Transformer Loss	1,098	1,550

Transformer Losses with Harmonic Distortion of Table A

Loss (W)	Amorphous Metal	Silicon Steel
Hysteresis	99	155
Eddy Current	74	698
Total Core Loss	173	853
Coil Loss	1,553	1,671
Loading Level (%)	55	58
Total Transformer Loss	1,726	2,524

Advantages

- **No Need for Added Devices such as Isolation Transformers, Harmonic Filters**
 - ▣ **30% less losses in harmonics rich environment**
- **Lesser heat generation due to lower losses**
 - ▣ **Slower ageing of insulation**
 - ▣ **Longer Life**
- **Superior electrical performance under harmonics condition**
- **Lesser Magnetizing current**

Power Factor

Power Factor Analogy

$$\text{Power factor} = \frac{\text{kW}}{\text{kVA}} = \frac{\text{kW}}{\text{kW} + \text{KVAr}} = \frac{\text{Beer}}{\text{Beer} + \text{Foam}}$$

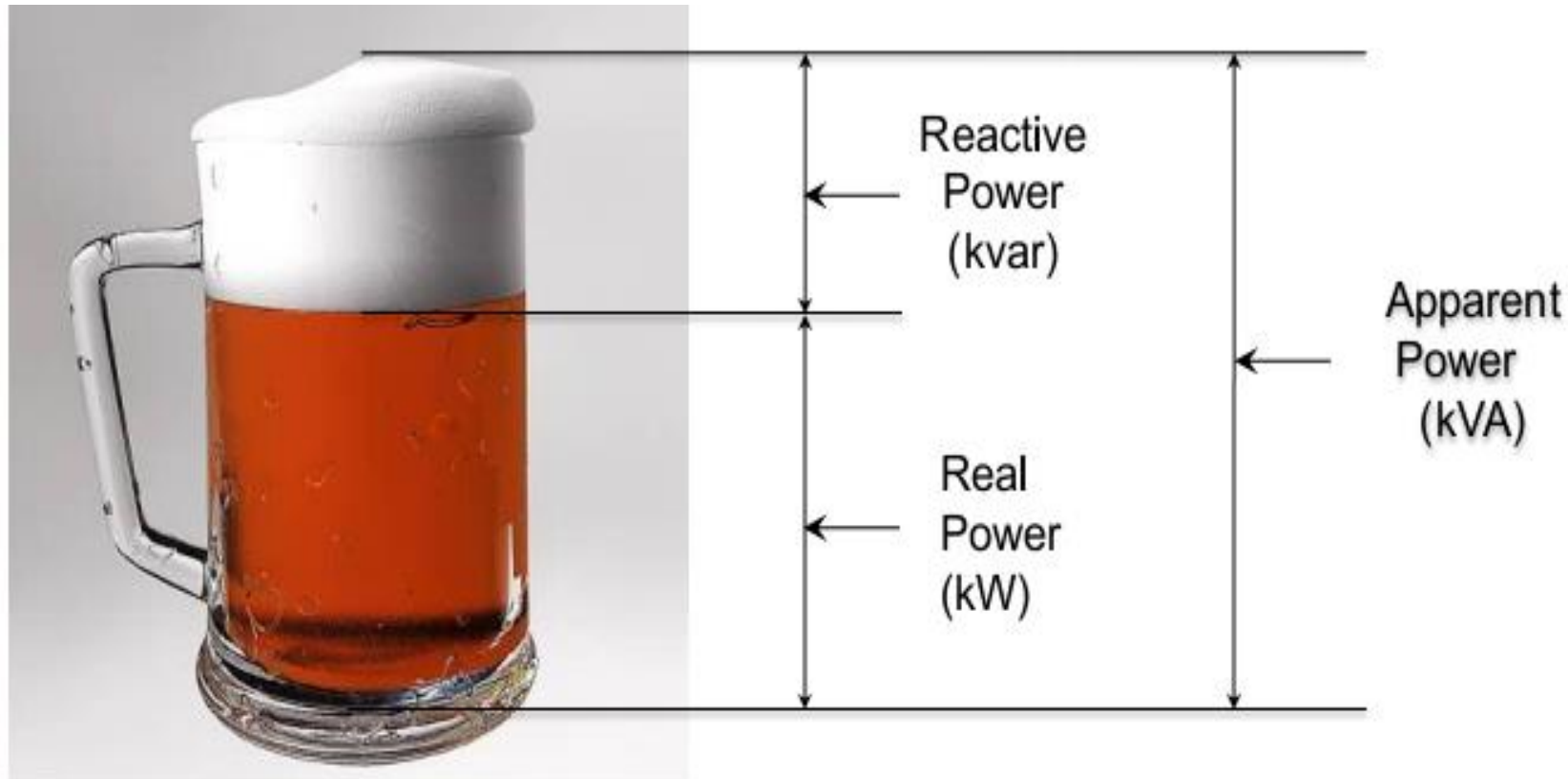

PF Compensation methods

- **3 methods**
 - **Centralized compensation**
 - **Distributed compensation**
 - **Mixed compensation**

Power Factor Compensation

Centralized compensation

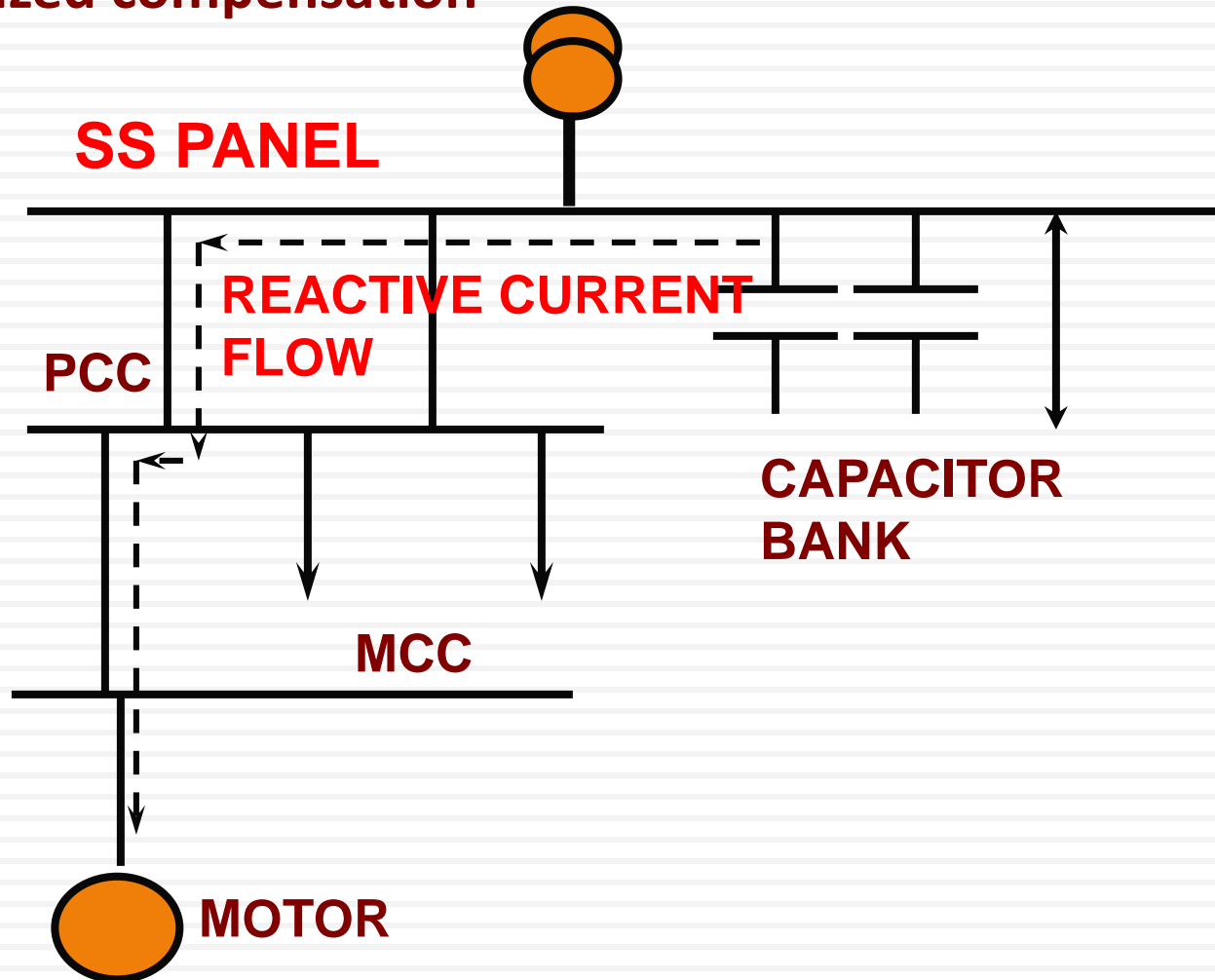

- Advantages
 - ▣ Easy P.F maintenance
 - ▣ Capacitor maintenance easy
- Disadvantages
 - ▣ More voltage drop in distribution
 - ▣ Over heating of cable resulting in failure
- Suitable if distance between PCC and MCC is less

Power Factor Compensation

Distributed Compensation

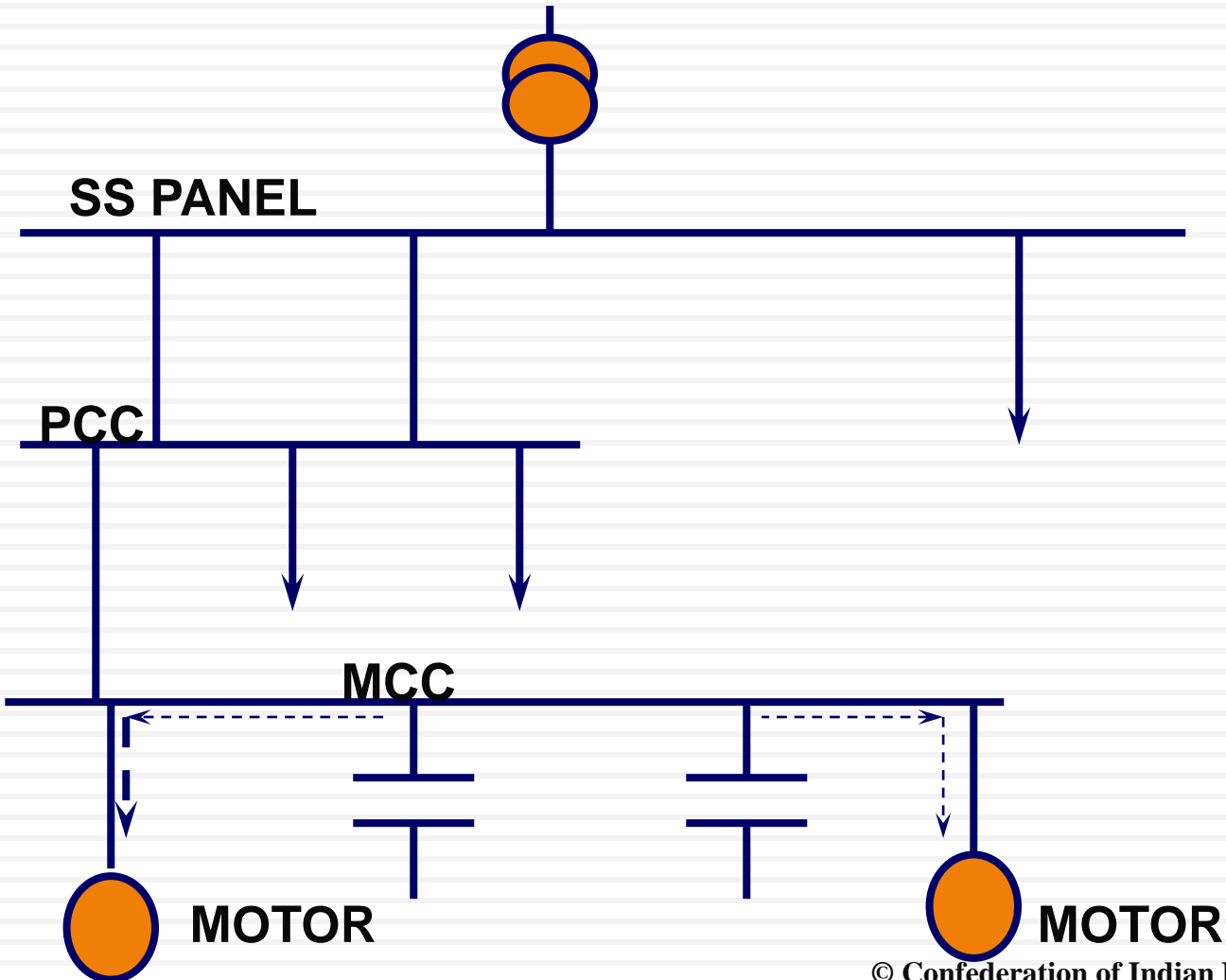

- Advantages
 - Minimum voltage drop
 - Low distribution losses
- Disadvantages
 - Maintenance is difficult
- Applicable where distribution is remote

Power Factor Compensation

Mixed Compensation

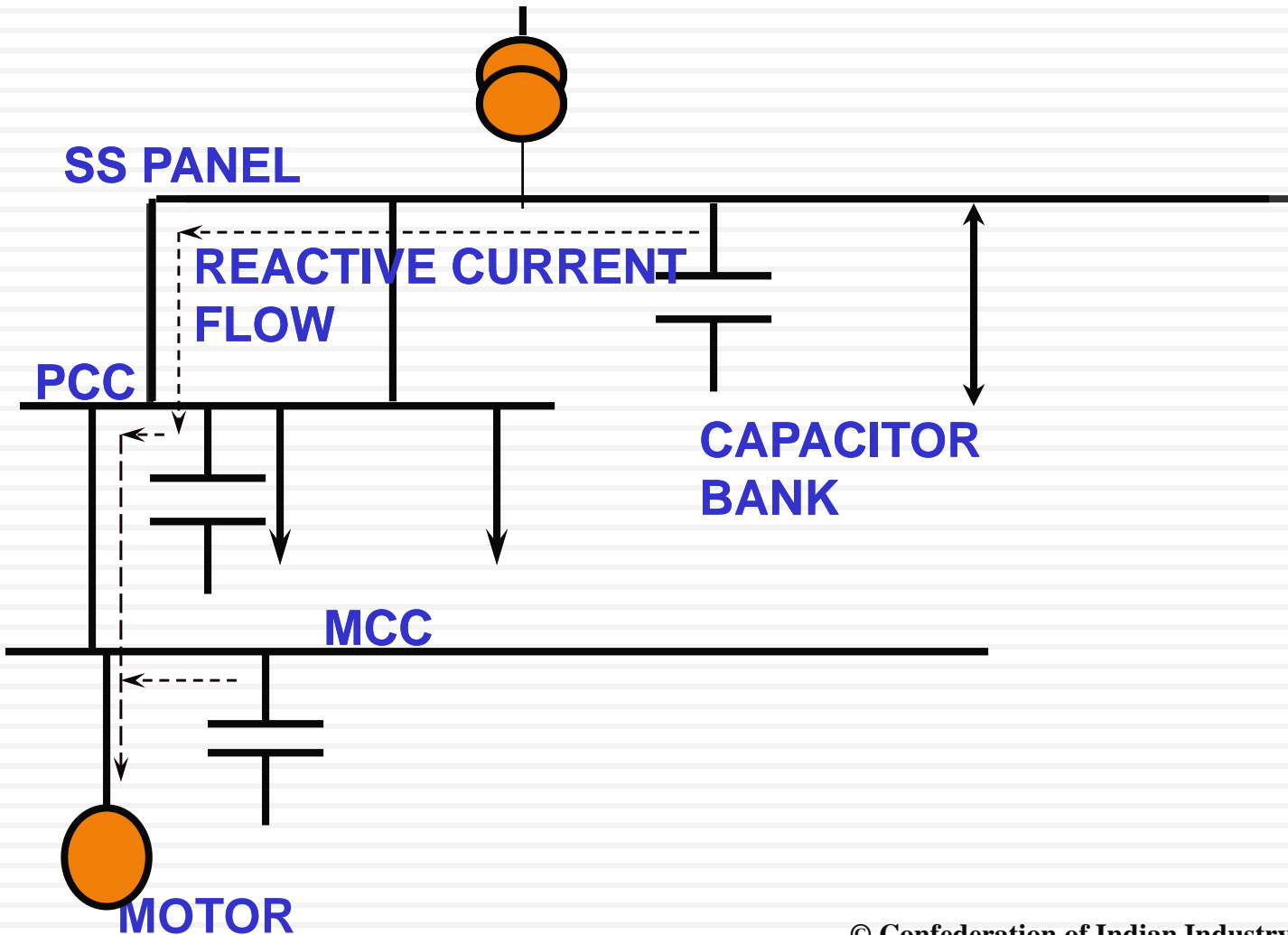

□ Advantages

- Good P.F control
- Easy maintenance
- Low distribution losses
- Common in Continuous Process industry

Case Study-Improvement of Overall PF and Reduction of MD

- **Case Study**
 - Monthly Avg PF maintained at 0.96
 - Sanctioned MD : 7300 kVA
 - Min demand charges : 75% (5475 kVA)
- **Recorded monthly MD**
 - 6800 kVA
 - High demand charges: Rs. 250/kVA
- **Action taken**
 - Installed additional capacitor banks & APFC to improve PF
- **PF improved to 0.99**
 - kVA demand reduced by 240 kVA

Case Study-Improvement of Overall PF and Reduction of MD

- **Additional benefits**
 - **Reduced voltage drop in feeders**
 - **Feeder loss reduction**
 - **Cushion for capacity expansion**

Annual Savings	-	10.30 Lakhs
Investment	-	15.0 Lakhs
Payback	-	18 months

Capacitor Selection PF improvement benefits on system losses

- Chart Method
- Formula Method
 - ▣ Capacitor required (KVAR)
$$= kW \times \{ \tan \cos^{-1} \Phi_1 - \tan \cos^{-1} \Phi_2 \}$$

Cos Φ_1 – Present power factor
Cos Φ_2 – Desired power factor
- Benefits of Power factor Improvement
 - ▣ Lower utility fees
 - ▣ Increased system capacity
 - ▣ Reduced system losses

$$\begin{aligned} & \% \text{ Reduction in system distribution losses} \\ & = 100 - 100 \times \frac{(\text{Present Pf})^2}{\text{New Pf}} \end{aligned}$$



Harmonics

What are harmonics?

Harmonics

- ❑ Normal Supply system operates at 50 Hz
- ❑ The Harmonics are sinusoidal waves that are integral multiples of fundamental frequency (150 Hz, 250Hz, 350Hz ...)
 - ❖ 50hz fundamental wave
 - 3rd Order Harmonics =150hz ,5th Order Harmonics =250hz, 7th Order Harmonics = 350hz etc.
- ❑ Pollution in Electrical System
- ❑ The overall impact of Voltage/ current harmonic distortion on a power system wave form is called as Total Harmonic Distortion(THD)/Total Demand distortion(TDD)

Fundamental waveform

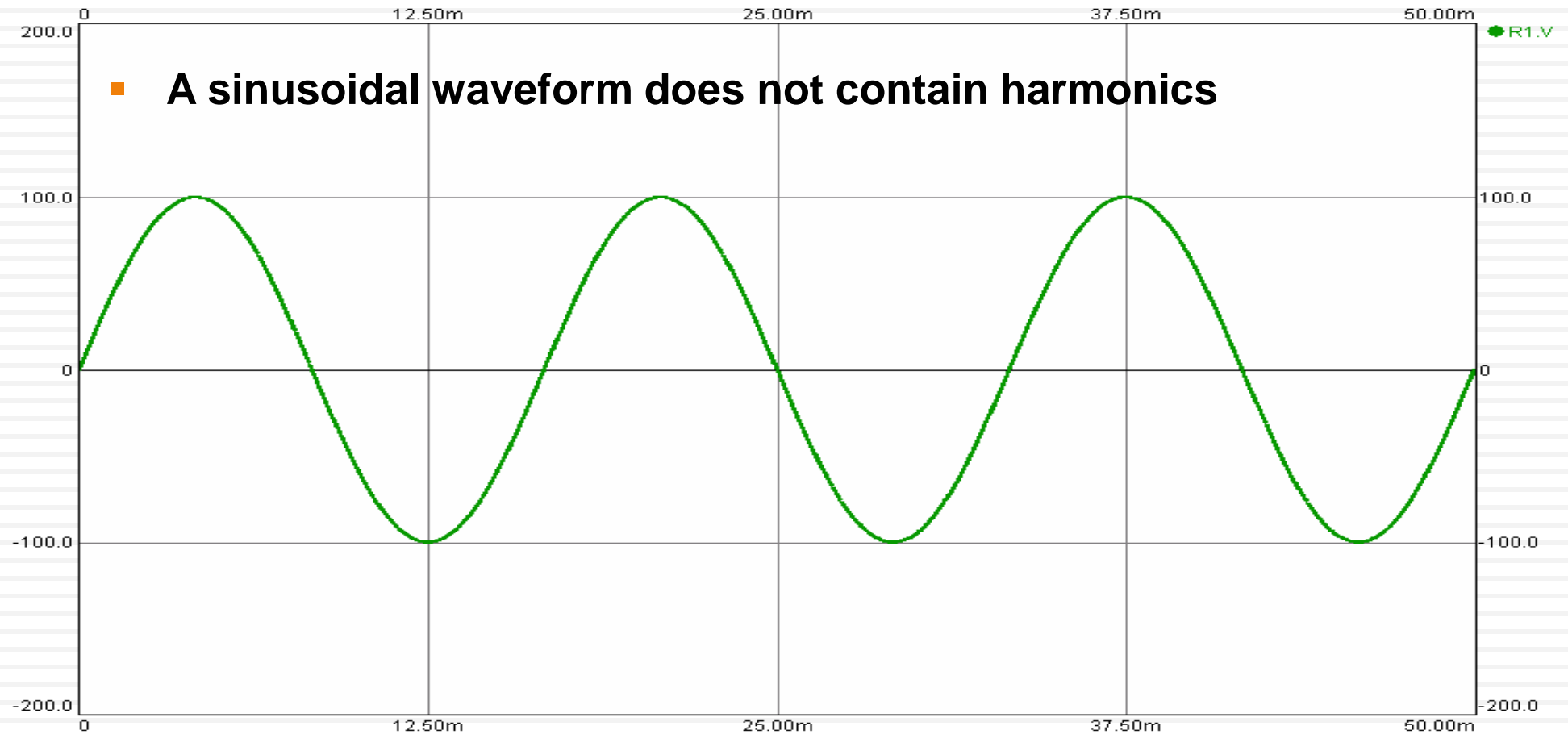

This is an example of a linear load

Fundamental, 5th, 7th & 11th harmonics

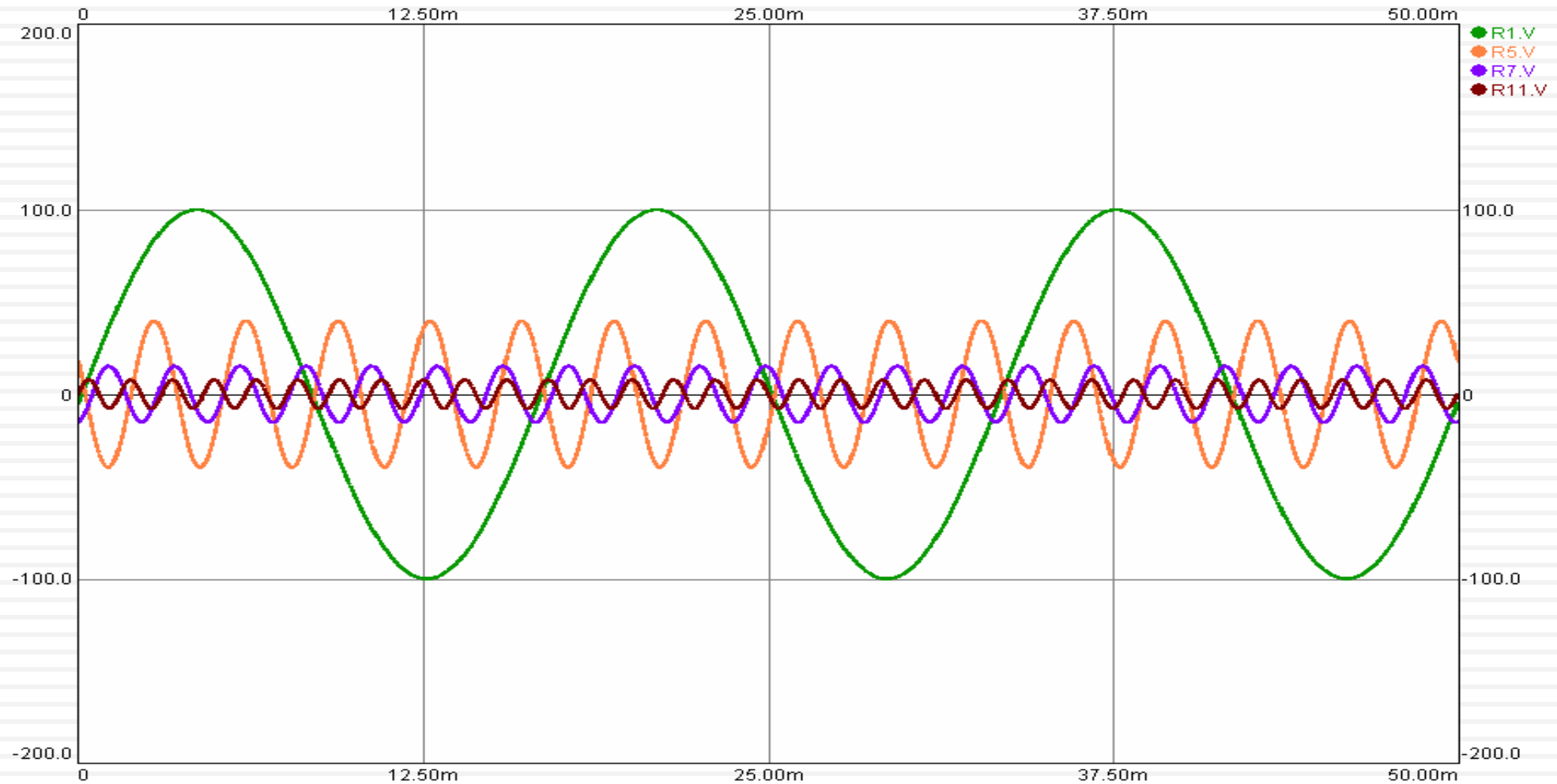

Resultant wave form

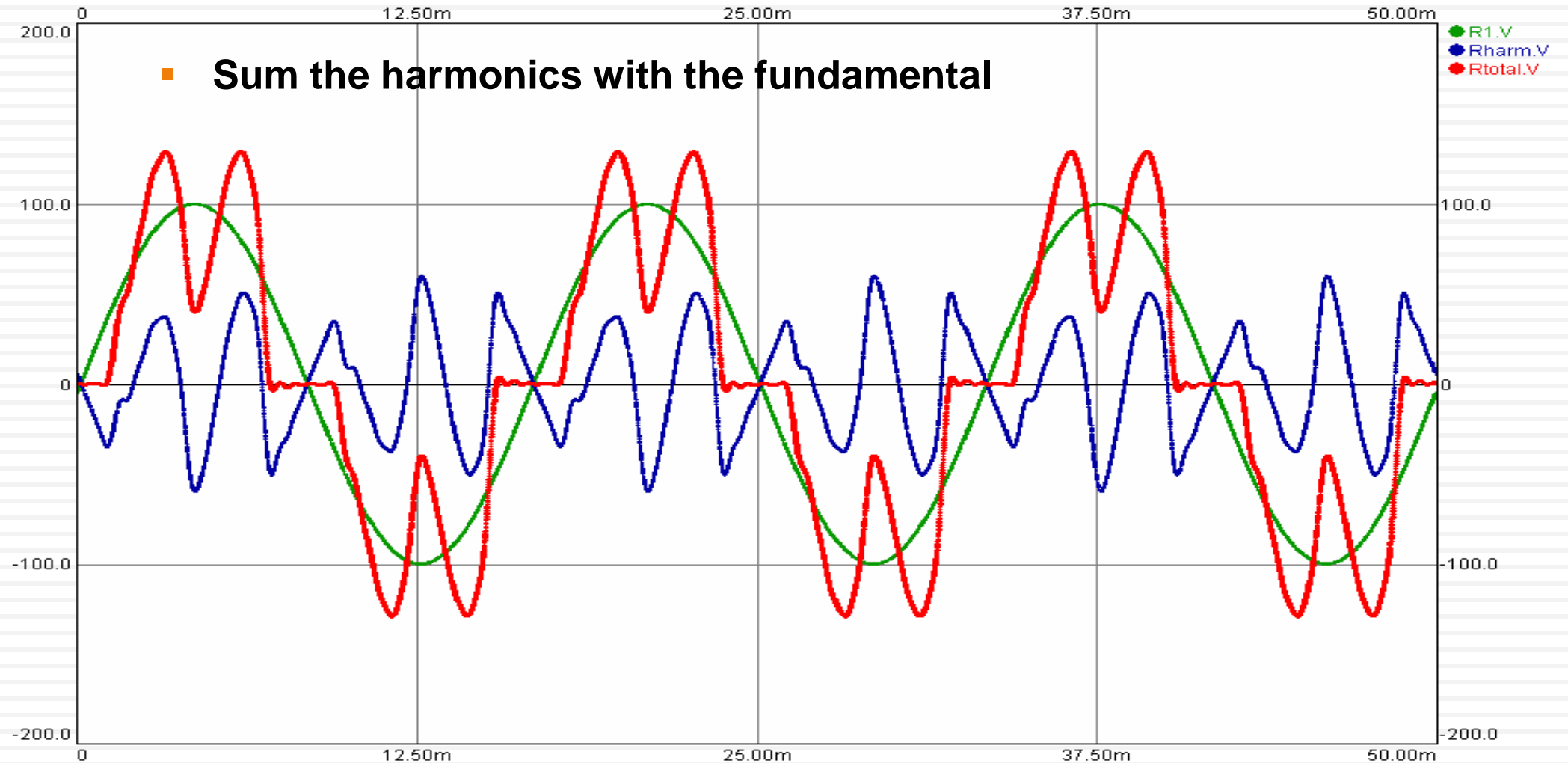

Harmonics Generation Sources

❑ Harmonics generation

❖ Linear voltage applied to non linear loads

➤ Draws non linear currents which results in distorted voltage

❑ Non-linear Loads

❖ Static Switches - Diodes, SCR's, GTO's, Transistors, IGBT's etc.

❑ Devices / Equipment



Welding Sets



Variable Speed
AC & DC Drives



SMPs



UPS Machines



LED Lights



Electronic
Ballasts

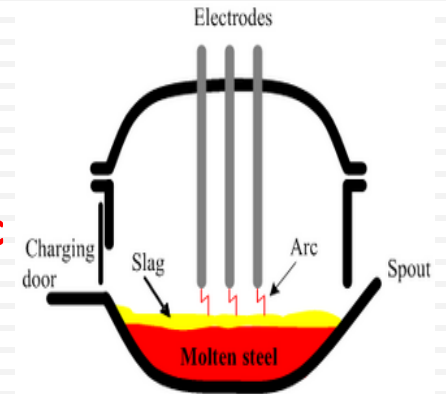

Arc Furnace

K-Factor in Transformers

- ❑ It is a simple numerical rating that indicates the extra heating caused by harmonics
- ❑ Transformers ability to handle the extra heating is determined by a K factor rating

- ❑ **K-1**

- ❑ **K-5**

Different types of Load	K Factor
Electric discharge lighting, UPS with optional input filtering	K-4
Welders, Induction heating equipment, PLCs and solid state controls (other than variable speed drives)	K-4
Telecommunications equipment (e.g. PBX) , UPS without input filtering	K-13
Multi wire receptacle circuits supplying inspection or testing equipment on an assembly or production line	K-13
Mainframe computer loads, variable speed drives	K-20
Multi wire receptacle circuits in critical care areas and operating/recovery rooms of hospitals	K-20

Effects of Harmonics on Power Factor

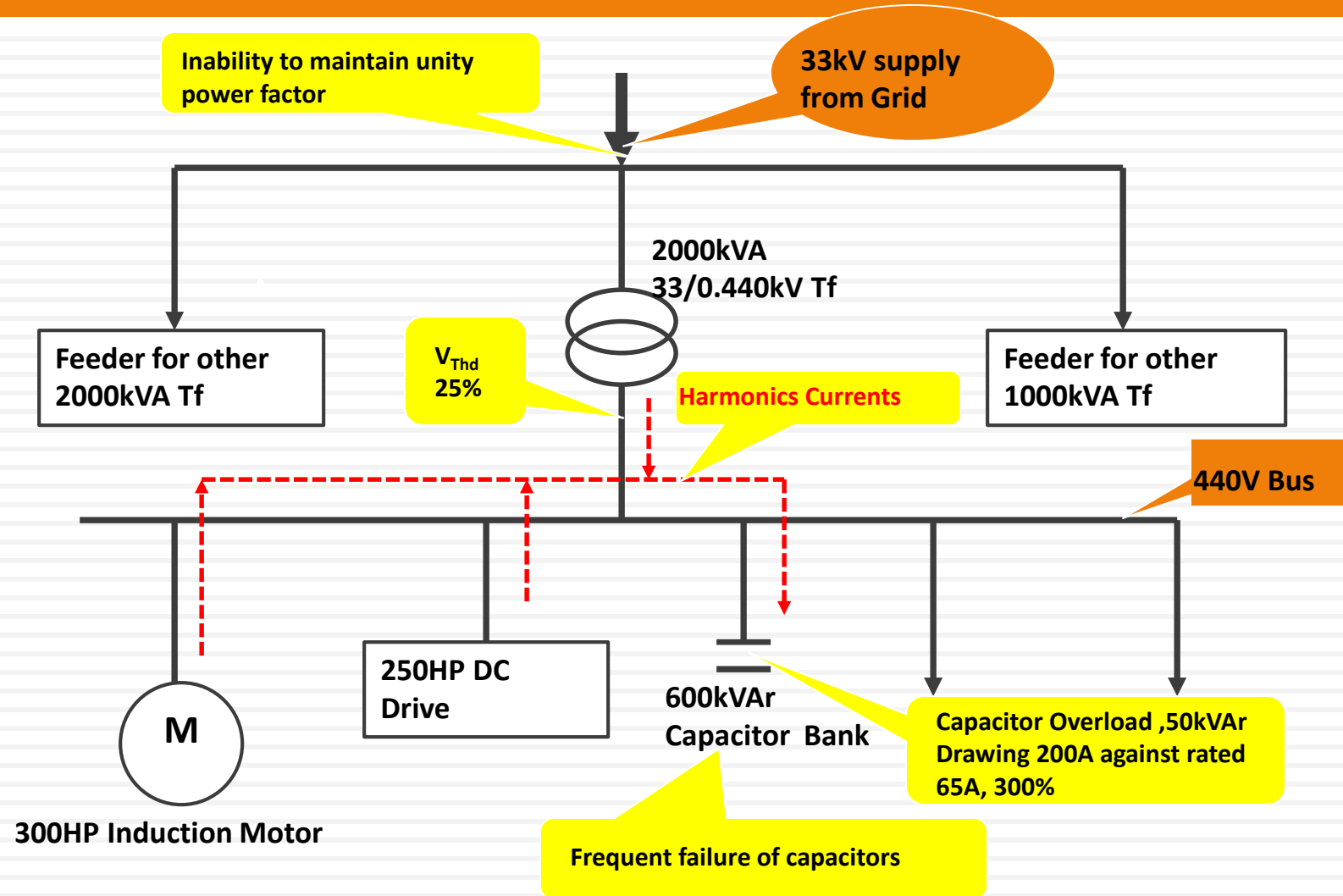

Effects of Harmonics on Power Factor

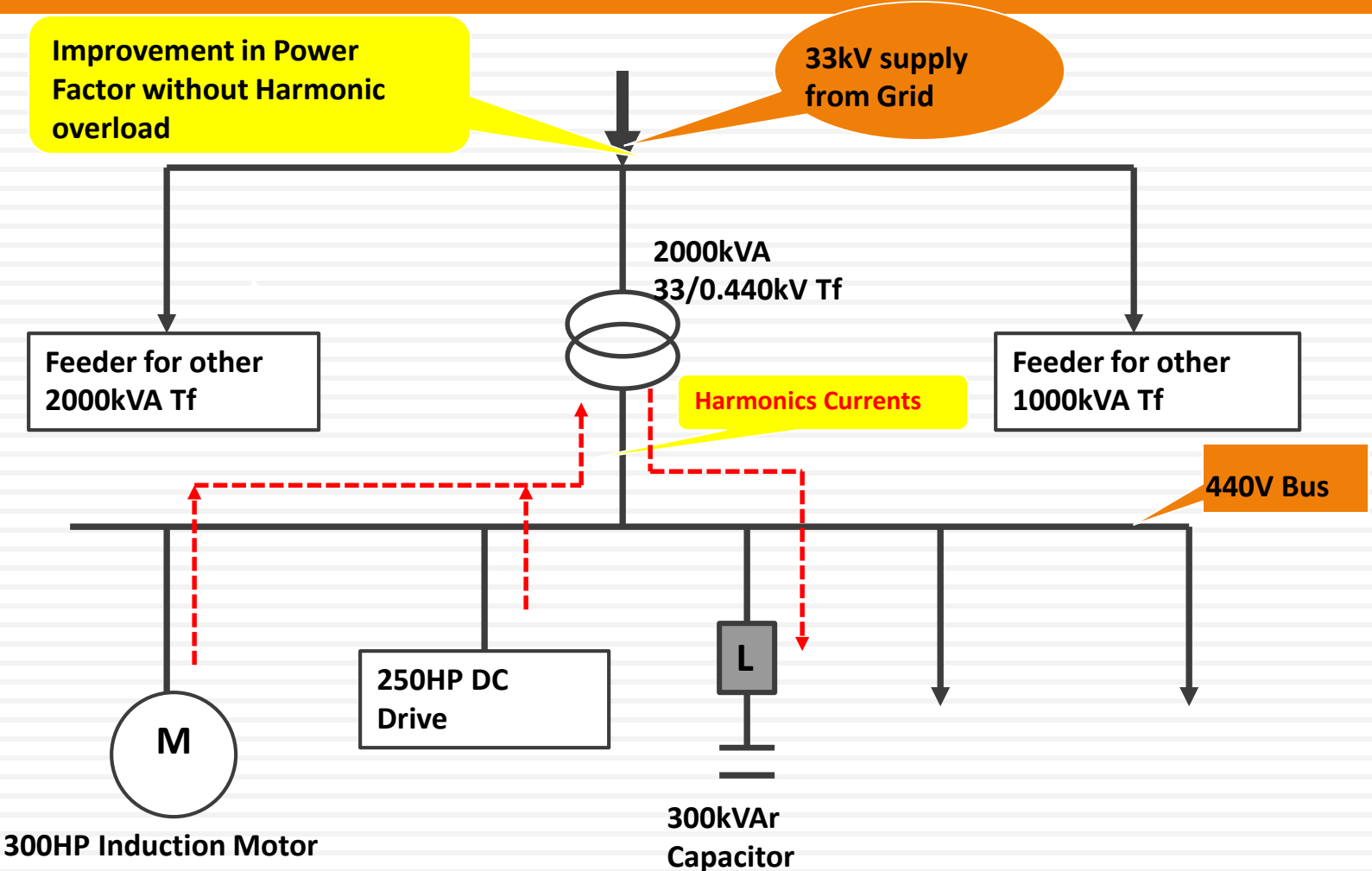

Harmonic Distortion - IEEE Std. 519-2014

Voltage Distortion limits

Bus Voltage at PCC	Individual Harmonic %	Total Harmonic Distortion THD %
$V \leq 1.0 \text{ KV}$	5	8
$1 \text{ kV} < V \leq 69 \text{ kV}$	3	5
$69 \text{ kV} < V \leq 161 \text{ kV}$	1.5	2.5
$161 \text{ kV} < V$	1	1.5



Harmonic Distortion - IEEE Std. 519-2014

Maximum Current Distortion limits in % of I_L for 120 v to 69 kV

Individual harmonic order (odd harmonics)						
I_{sc}/I_L	$3 \leq h < 11$	$11 \leq h < 17$	$17 \leq h < 23$	$23 \leq h < 35$	$35 \leq h \leq 50$	TDD
<20	4.0	2.0	1.5	0.6	0.3	5.0
20<50	7.0	3.5	2.5	1.0	0.5	8.0
50<100	10.0	4.5	4.0	1.5	0.7	12.0
100<1000	12.0	5.5	5.0	2.0	1.0	15.0
>1000	15.0	7.0	6.0	2.5	1.4	20.0

Even harmonics are limited to 25% of the odd harmonic limits above.

❑ Current Distortion, TDD

❖ Depends on I_{sc}/I_L ratio of

➤ Generally less than 15%

❖ TDD for current drawn from Transmission line at PCC is 8 %

Options for Reducing Harmonic Distortion

- ❑ **Use of Line Reactors**
- ❑ **Use of Harmonic mitigating/Phase shift transformers**
- ❑ **Installation of Harmonic filters**
 - ❖ **Passive filters**
 - ❖ **Active Filters**
- ❑ **Use of multi pulse converter**
 - ❖ **12 pulse, 18 pulse & 24 pulse**

Case Study

Implemented in Engineering Plant

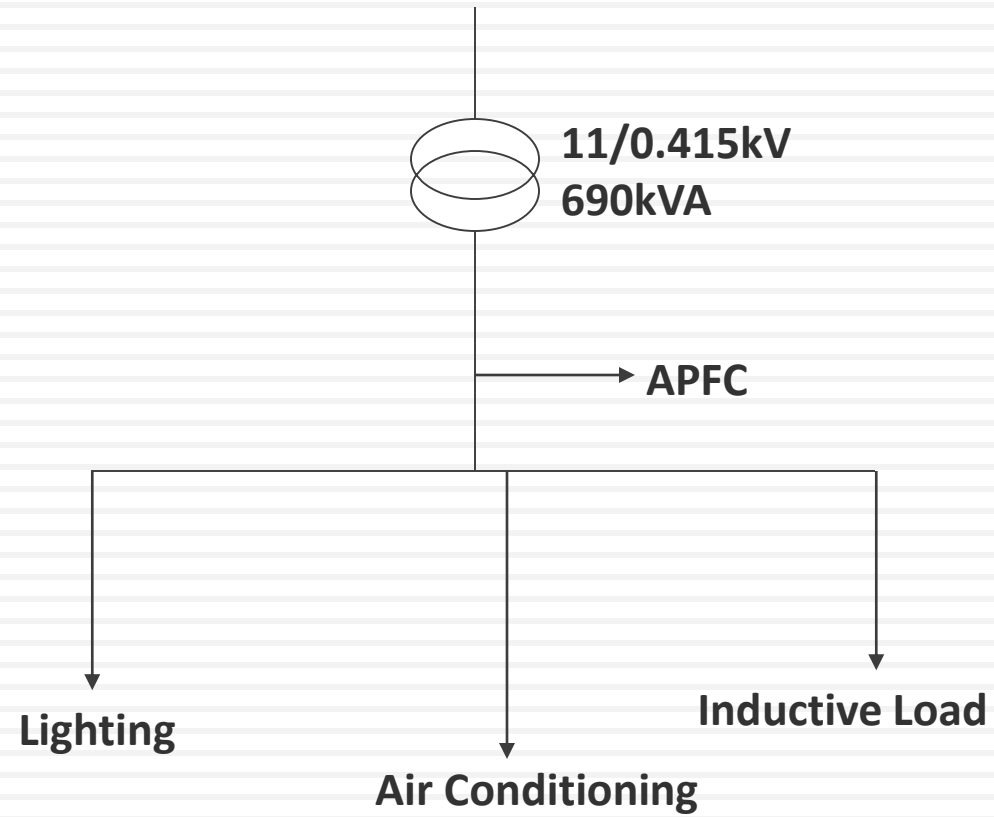

Harmonics Waveform

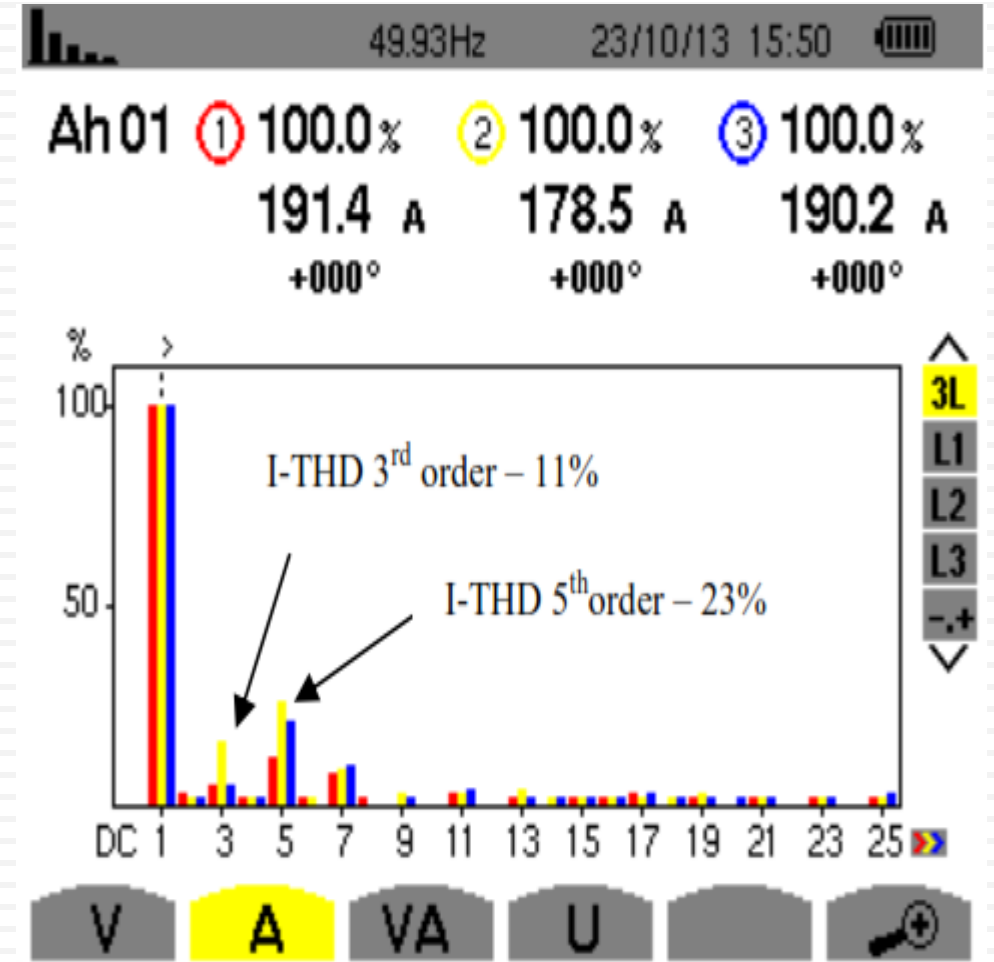
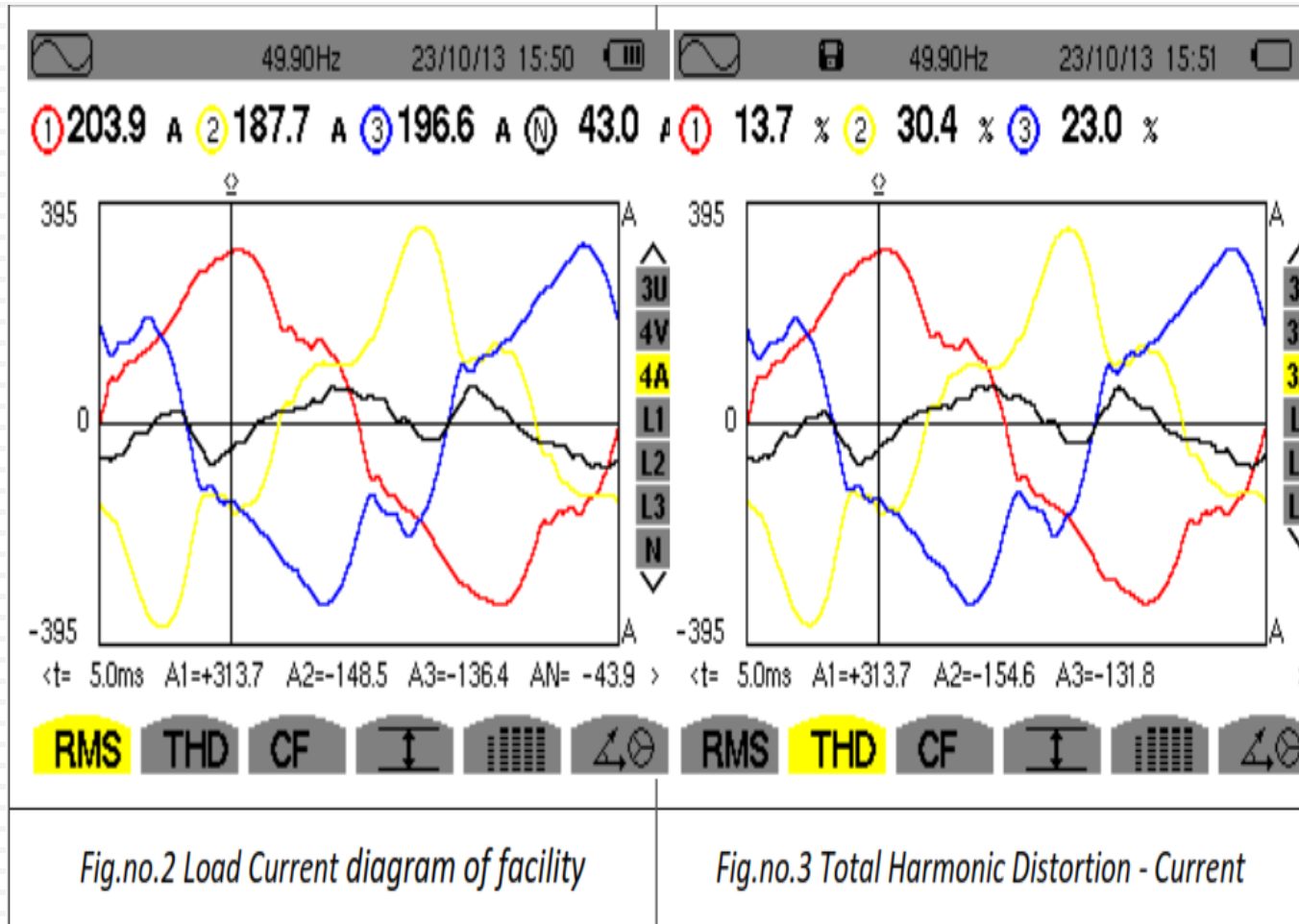

Installation of AHF

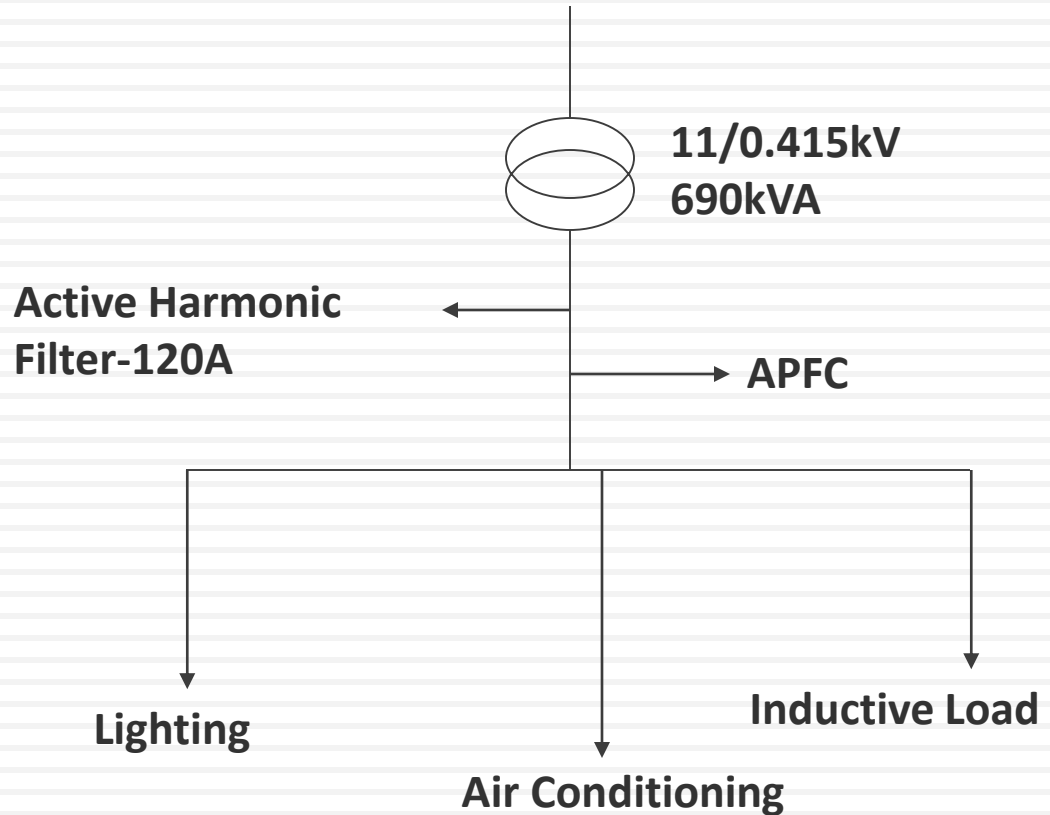

Waveform After AHF

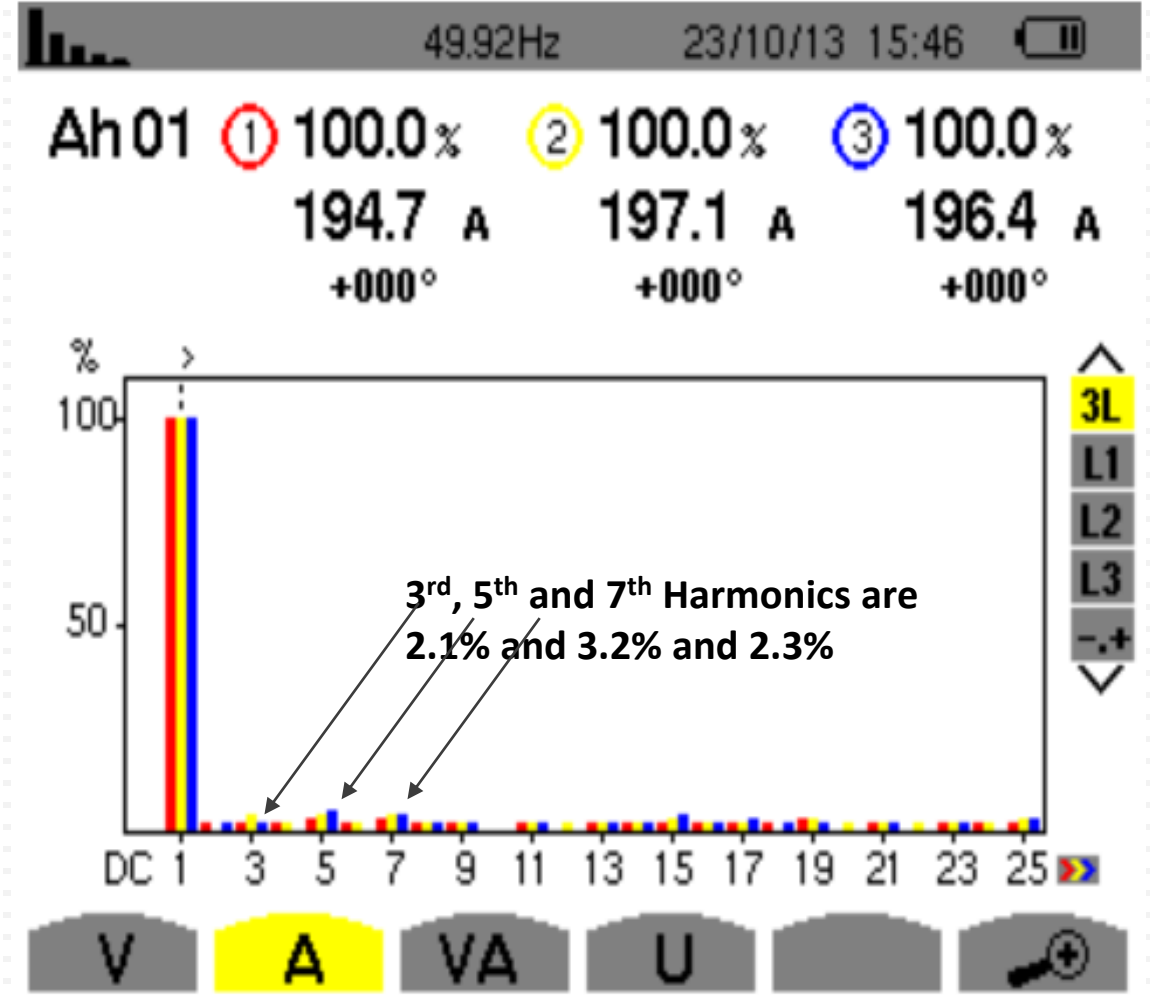
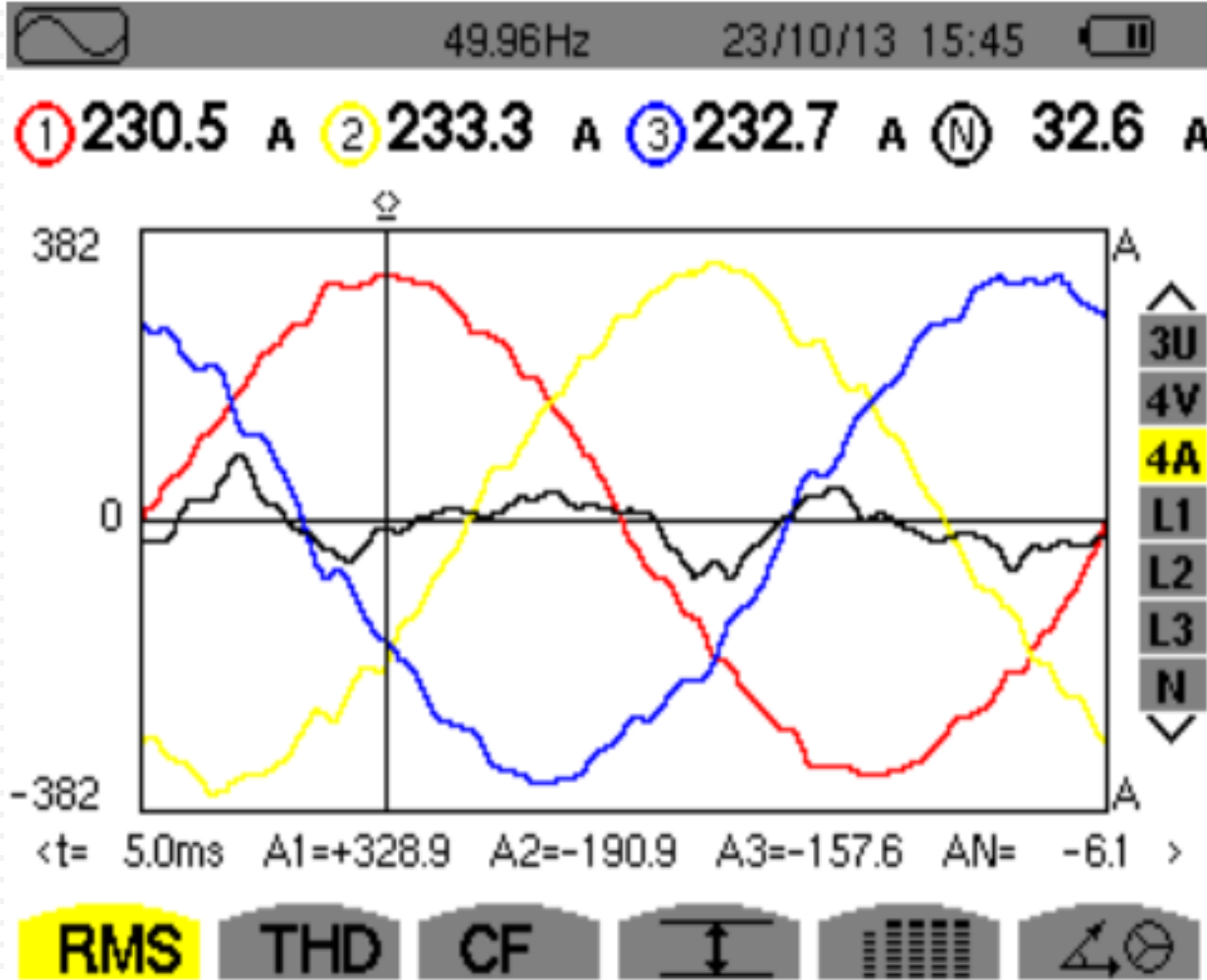

Cost Economics

□ Saving -12 kVAh

Annual Savings	:	Rs 7.88 Lakhs
Investment	:	Rs 7.50 Lakhs
Payback	:	12 Months

Motors



Why to have focus on motors ??

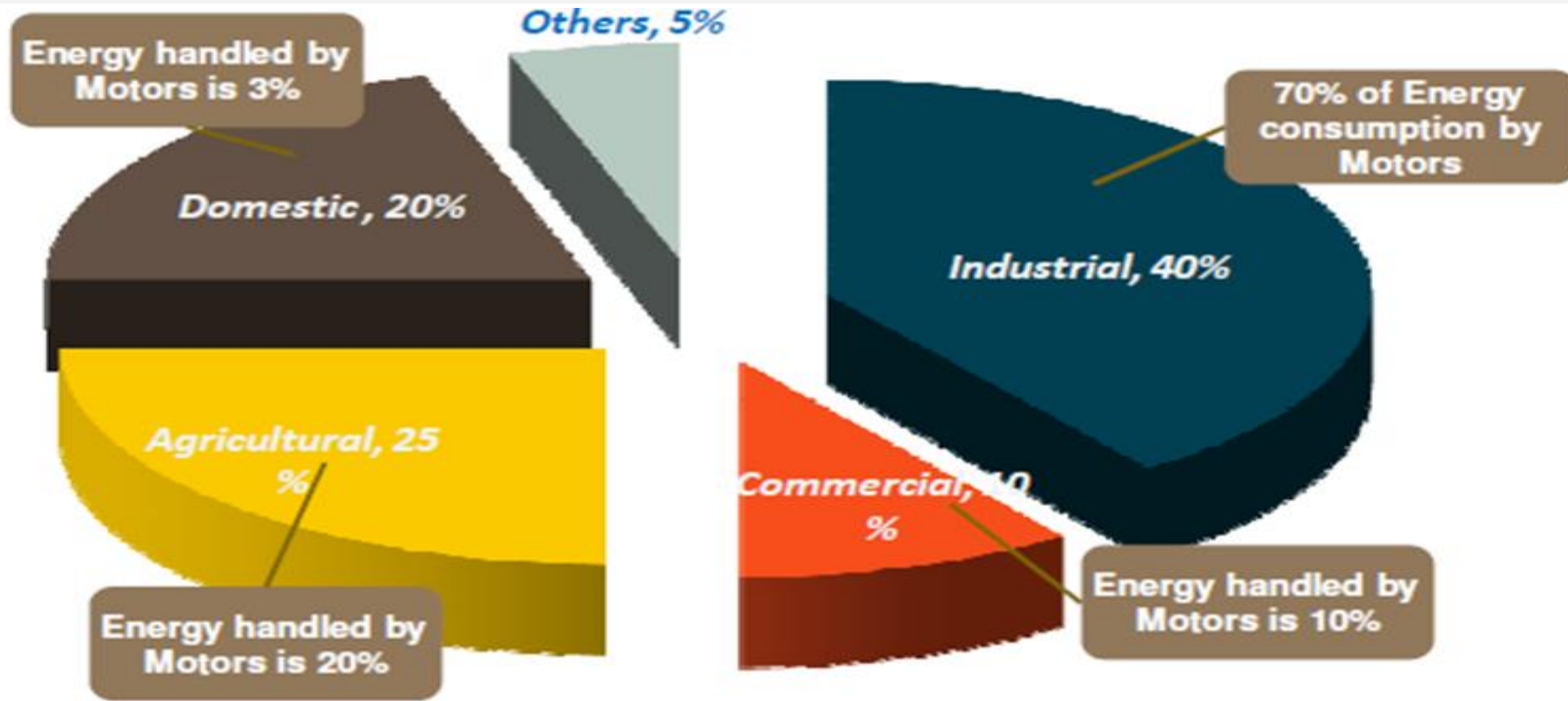

*Source:- International Copper Association

Capacity of Motor - Horse Power ?

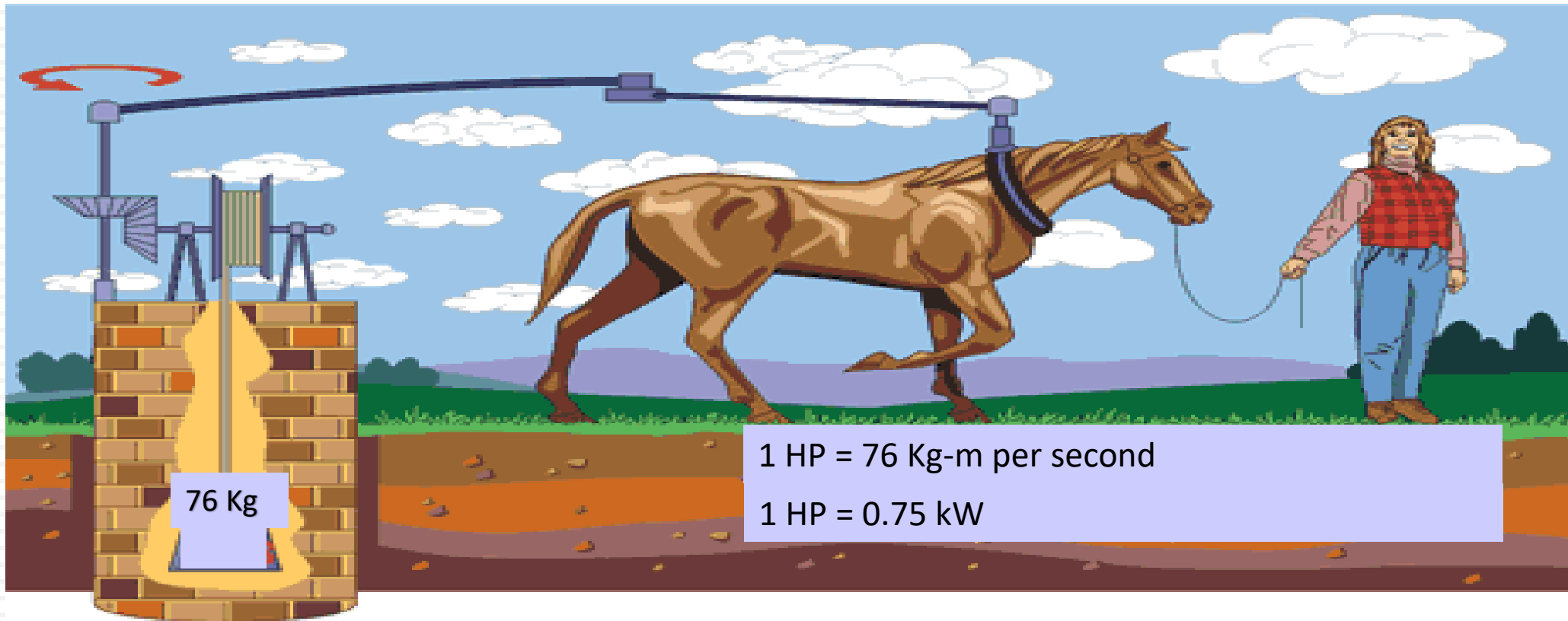

Work - Force applied over a distance
Power – Rate of doing work

Motor Efficiency

Effectiveness with which a motor
converts *Electrical energy* to
Mechanical energy

$$\text{Efficiency} = \frac{\text{Output Power}}{\text{Input Power}} \times 100$$

Output

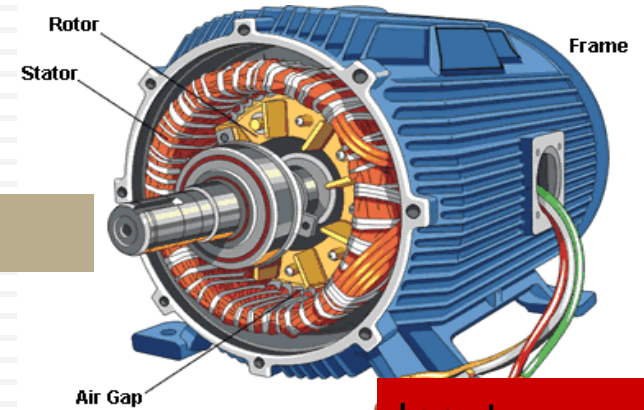

Input

Motor Losses

- **Current dependent -Copper losses**

Stator

Rotor

- **Voltage dependent -Iron losses**

Magnetization

Eddy Current

- **Friction and Windage losses**

Motor Power Loss Model

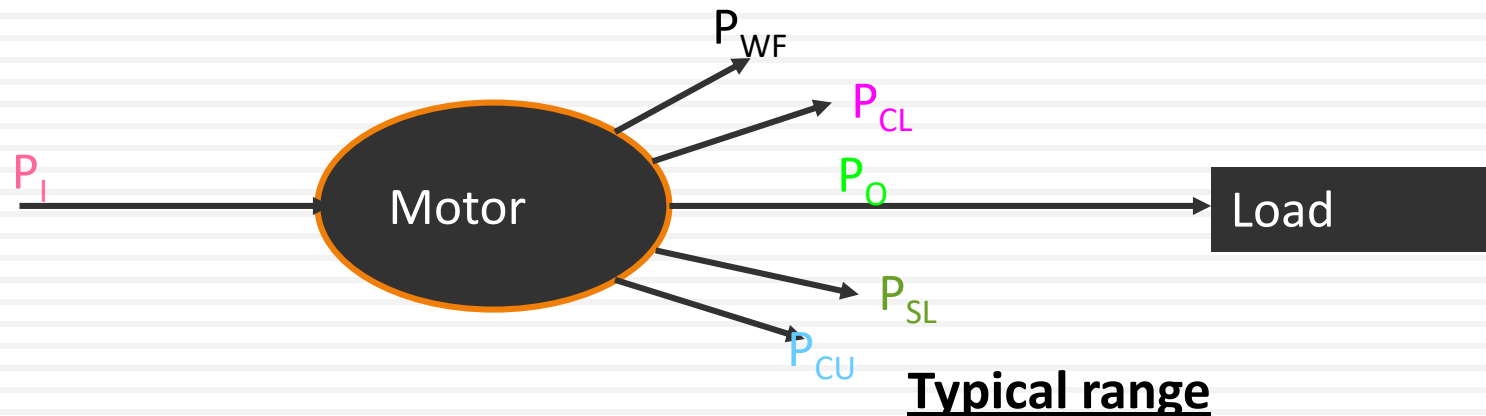

H_p	horsepower	5 - 200 HP
P_{wf}	windage/friction losses	2.6 - 0.3 %
P_{cl}	core losses (magnetization)	5 - 2.5 %
P_{sl}	stray load losses	2.2 - 0.5 %
P_{cu}	I^2R losses (copper losses)	9 - 3 %
P_{kl}	total losses	18.8 - 6.3 %
N	motor efficiency (p_o/p_i)	84 % - 94%

Why your motors are becoming less Energy Efficient?

1

- **Over Sized / Under loaded Motors**

2

- **Improper Supply Voltage**

3

- **Use of Less Efficient Motors**

4

- **Poor Power Factor**

5

- **Rewinding of Motors**

Performance of Motor at Partial Load

- Motor loading is critical factor
 - Motor η and power factor varies with % loading
- For lightly loaded motors
 - Voltage related losses - high
 - Power factor is very low
 - More copper losses
 - Motor operates in less efficiency range

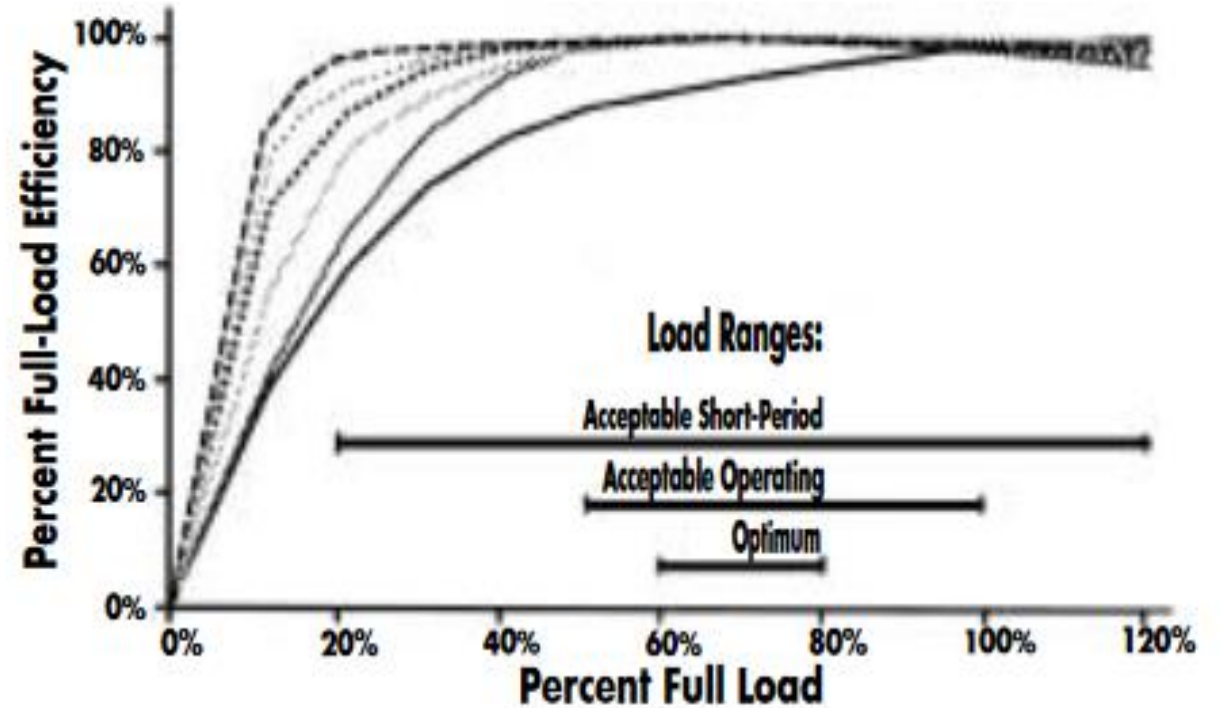

0-1 hp	10 hp	30-60 hp
1.5-5 hp	15-25 hp	75-100 hp

How to Find Out Motor Loading?

- A 3-Ph IM rated power for 75 kW, 415 V, 150A, 0.85pf and 92% draws 30 kW & 75 A.
- What is % loading on motor?
 - 65 %
 - 40 %
 - 50 %
 - 37 %

Analysis of Loading Pattern

□ Analysis of Load Pattern

- Measure kW input to motor using Portable Power Meter / Load Manager
- Estimate % loading
- Analyse Load pattern at different process conditions
- Record the minimum & maximum Loading

Optimization Of Lightly Loaded Motors

□ Options Based on

- Nature of load
- Load factor
- Economic option

□ Options

- Delta connection to permanent star connection
 - **Steady load application**
- Automatic star-delta-star converters
 - **variable loads**
- Soft starter cum energy savers
 - **High starting torque applications**
- Variable voltage devices
- Down sizing
- Overall voltage optimization

Delta & Star Motor Connection

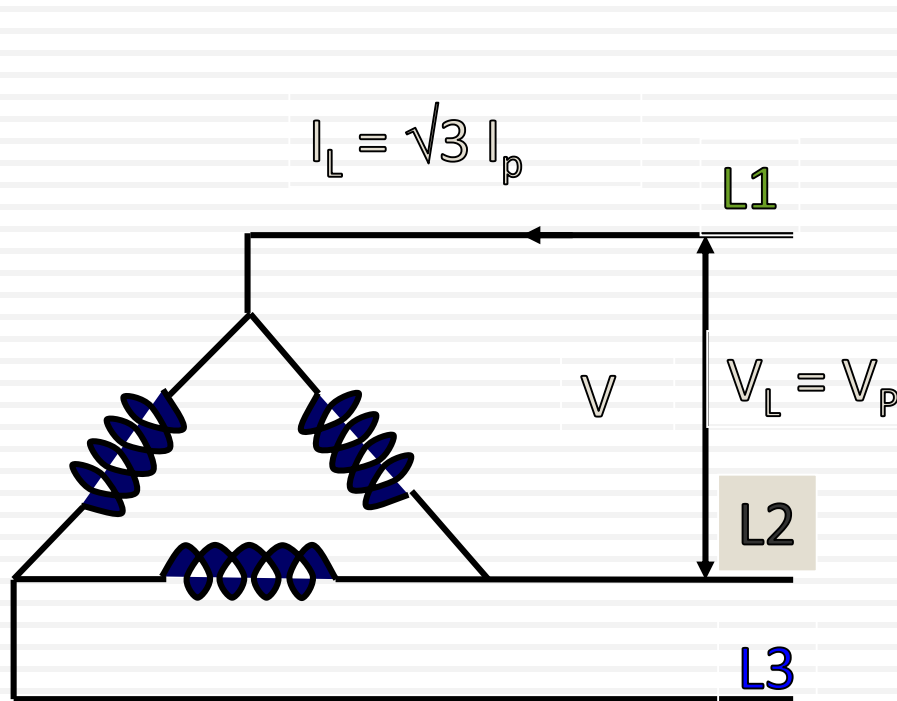

Delta connection

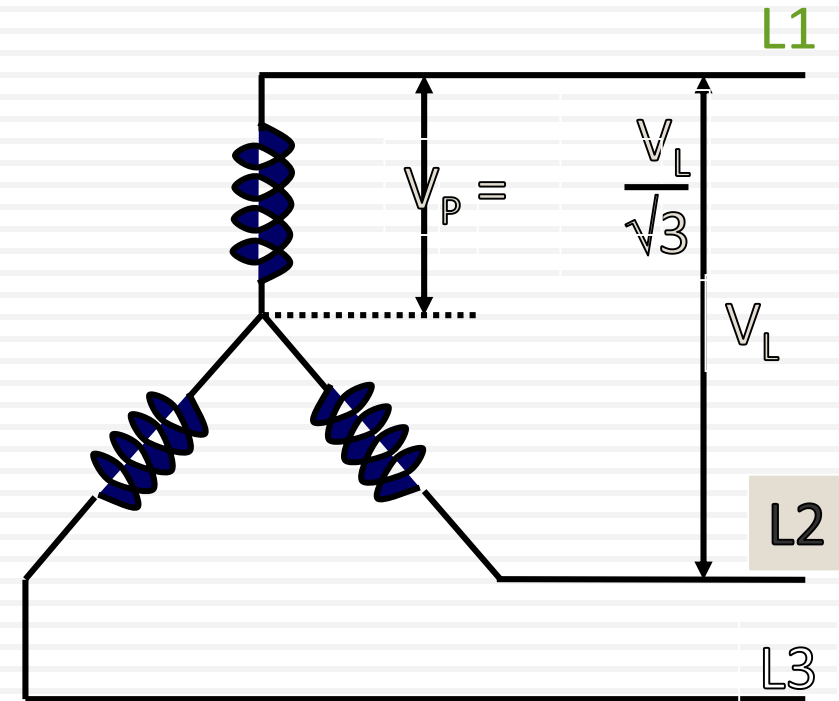

Star connection

Convert Delta To Star Connection at Lightly Loaded Motors

- ❖ Motors normally operated in delta mode
 - **Permanently Lightly loaded motors can be operated in star mode**
- ❖ Effect on motor performance operating in star mode
 - **Motor operating efficiency improves**
 - **Reduction in voltage related Iron losses**
 - **Reduction in Cu losses**

Case Study - Delta to Star Conversion

Before:

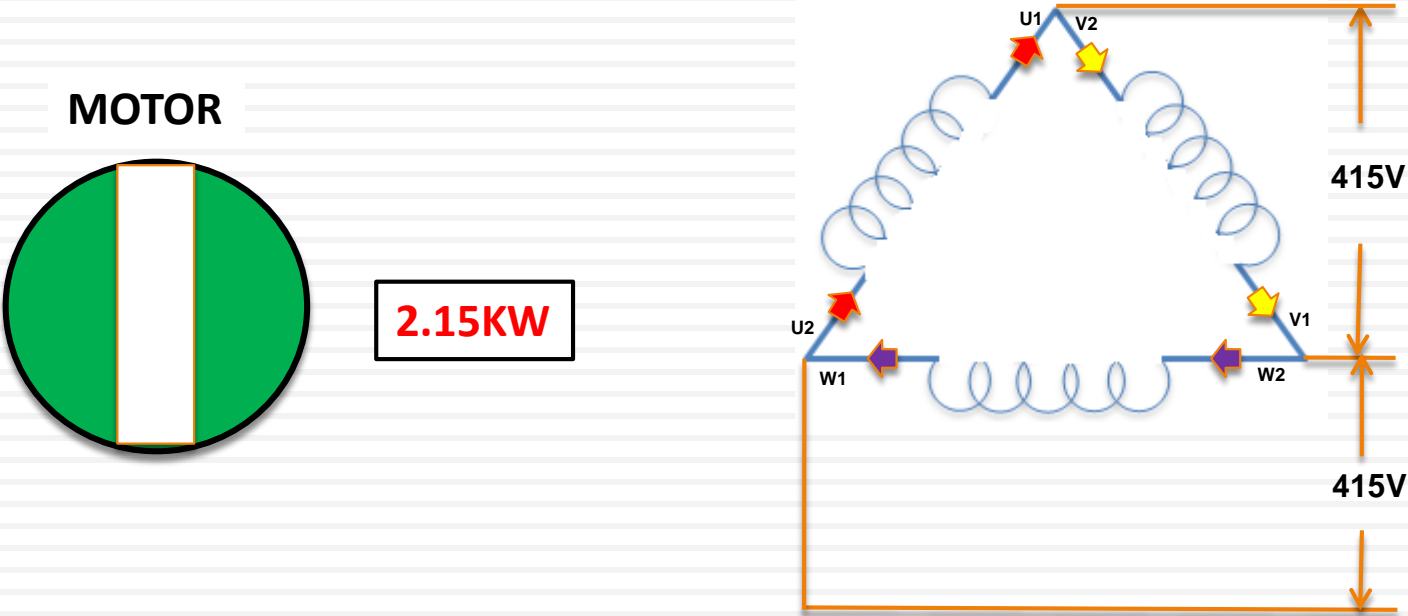

DELTA CONECTION OF MOTOR



Case Study - Delta to Star Conversion

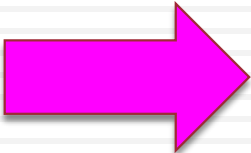
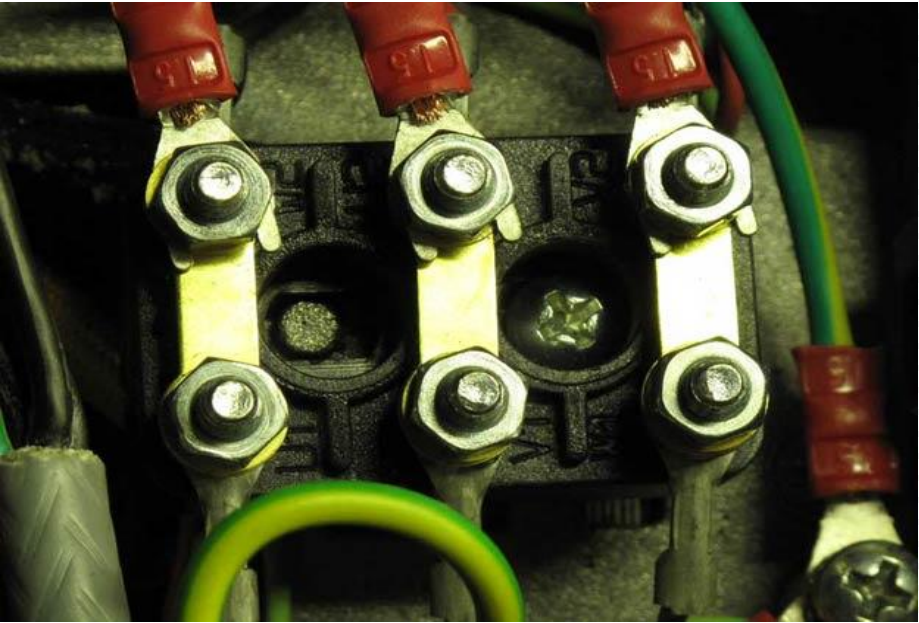

Case Study - Delta to Star Conversion

After:

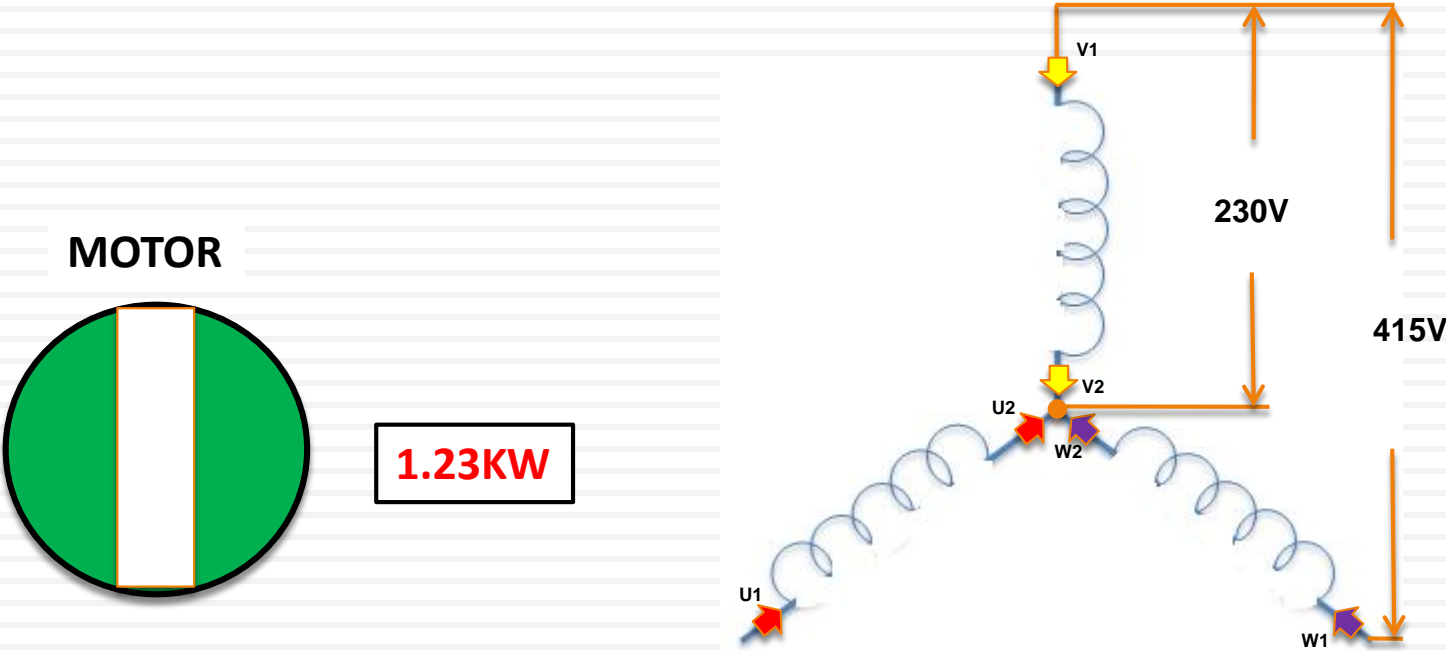

STAR CONNECTION OF MOTOR



Case Study - Delta to Star Conversion

S.NO	EQUIPMENT	RATED KW	DELTA MODE POWER	STAR MODE POWER	POWER SAVING IN KW	ENERGY SAVING PER ANNUM IN KWH	Cost Savings
1	COOLING FAN - 1	3.7	2.15	1.23	0.92	7286	Rs 35000
2	COOLING FAN - 2	3.7	2.07	1.16	0.91	7207	Rs 34500
		TOTAL				14494	Rs 69 500

*Run hours taken 330days @ 24Hrs per day

Energy Efficient Motor

- Use of lower loss silicon steel
- Longer core
- Thicker wires
- Thinner laminations
- Smaller air gap between stator and rotor
- Improved winding and lamination designs to minimize energy consumption

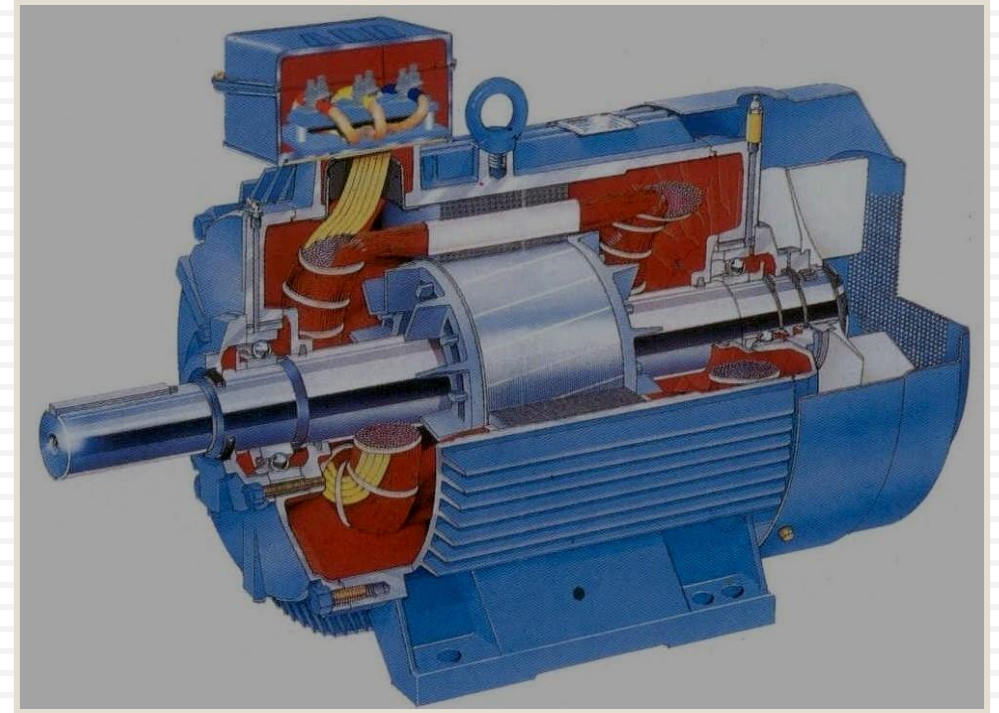

Energy Efficient Motor

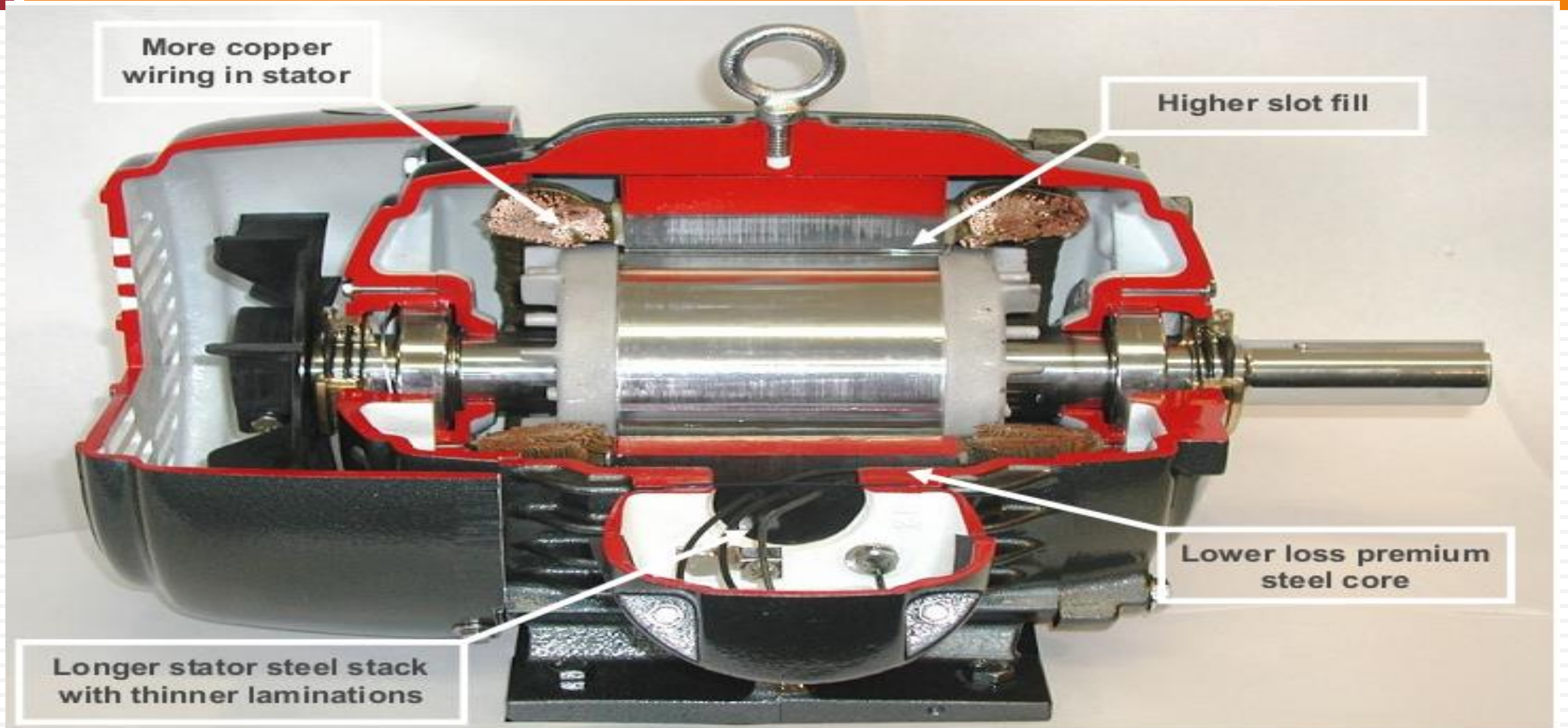

Energy Efficient Motor

- Lesser slip
- Copper instead of aluminum bars in the stator
- Improved fan design
 - ▣ Cooler operation & Increases motor insulation life
- 1.15 service factor
 - ▣ Greater flexibility in handling voltage variations and imbalances
- High power factor
 - ▣ Eliminate need for PF correction

Energy Efficient Motors

New efficiency classes defined by IEC -60034

Super premium efficiency *	IE4	Super premium efficiency
Premium efficiency	IE3	Premium
High efficiency	IE2	Comparable to EFF1
Standard efficiency	IE1	Comparable to EFF2

IEC standard indicated a Super Premium class with 15% lower losses than the IE3

IE efficiency classes for 50 Hz 4-pole motors

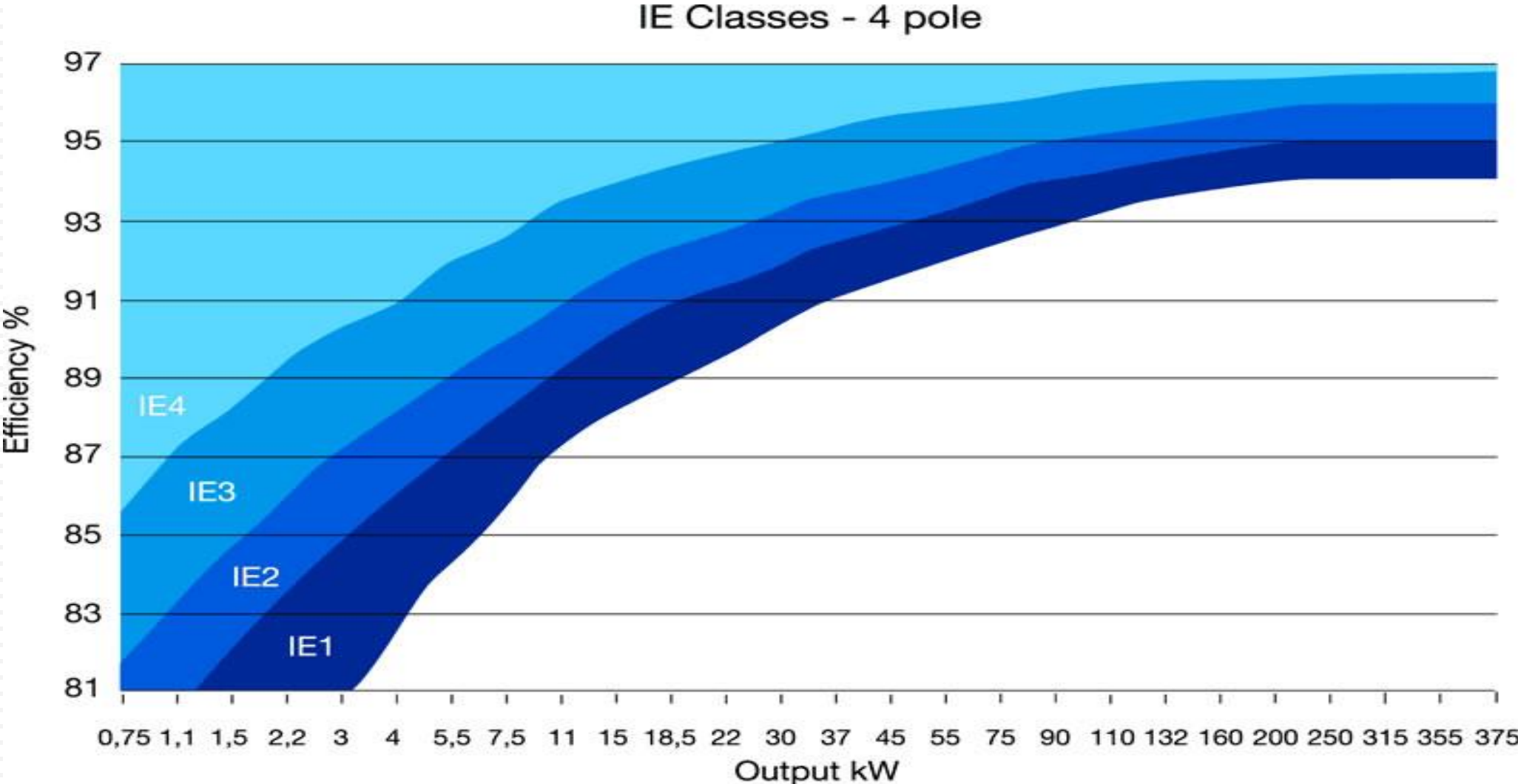

Loading vs Efficiency

- **Motors are generally loaded between 50 – 80%**
 - **Due to Higher starting Torque**
 - **Varying process requirements**
- **Efficiency of Energy Efficient Motors is higher than conventional motors and flat between 50 – 100% loading**

Energy Efficient Motor – Part load Operation

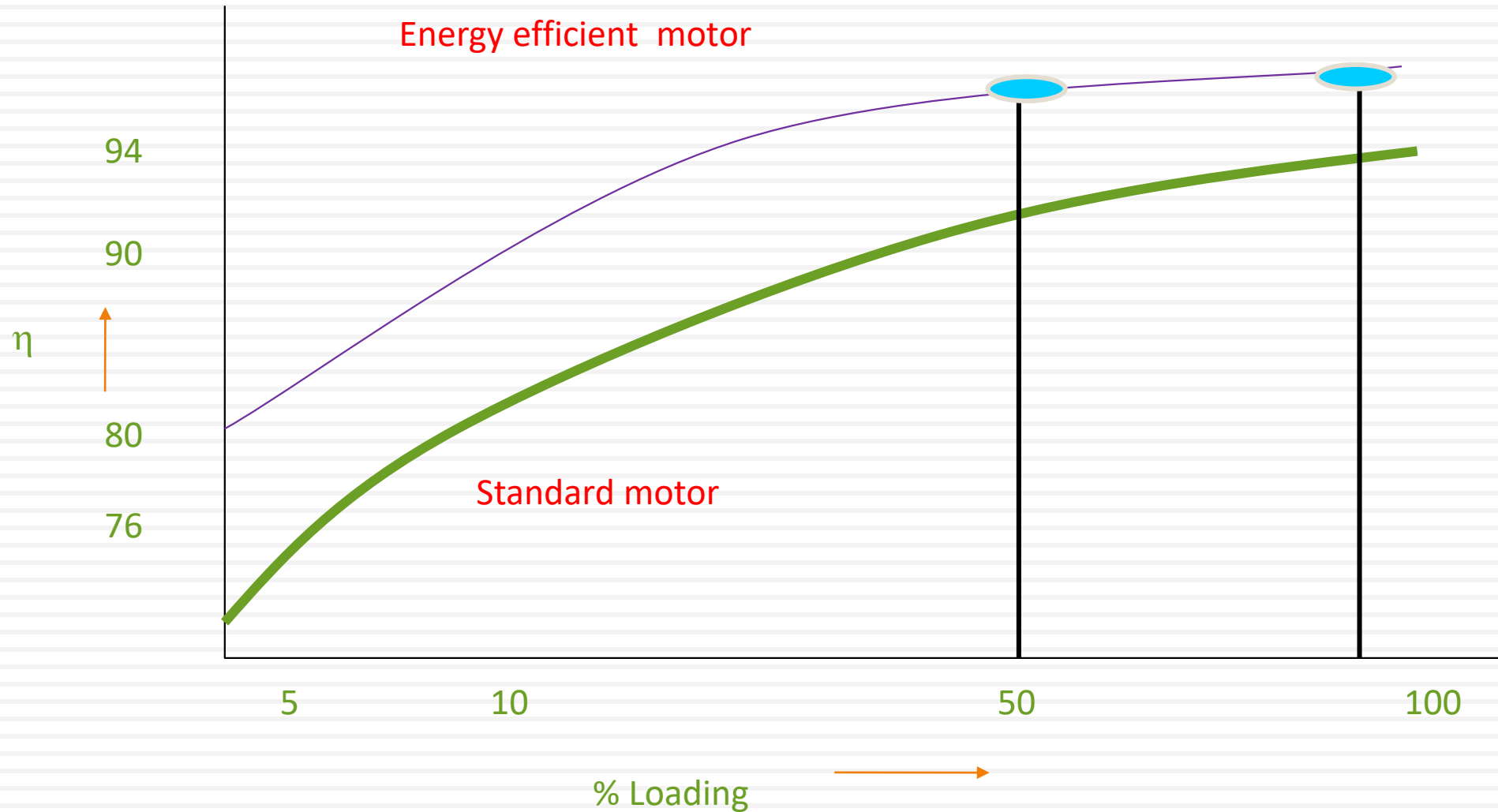

When to Install EE Motors?

- **New Projects**
 - ▣ **EE Motors ideally suited**
- **Rewinding of Old motors**
 - ▣ **In case of Normal Failure**
 - ▣ **Fit case for Replacement after rewound 5 times**



Case Study-Replace old motors with Energy Efficient Motors

- Implemented in one of the Automobile plant
- Old motors
 - More than 20 years old
 - Rewound for many times
 - Reduction in efficiency
- Replaced 9 numbers of motors

Annual Saving	-	Rs 14.0 Lakhs
Investment	-	Rs 25.0 Lakhs
Payback period	-	22 Months

PERMANENT MAGNET SYNCHRONOUS MOTOR

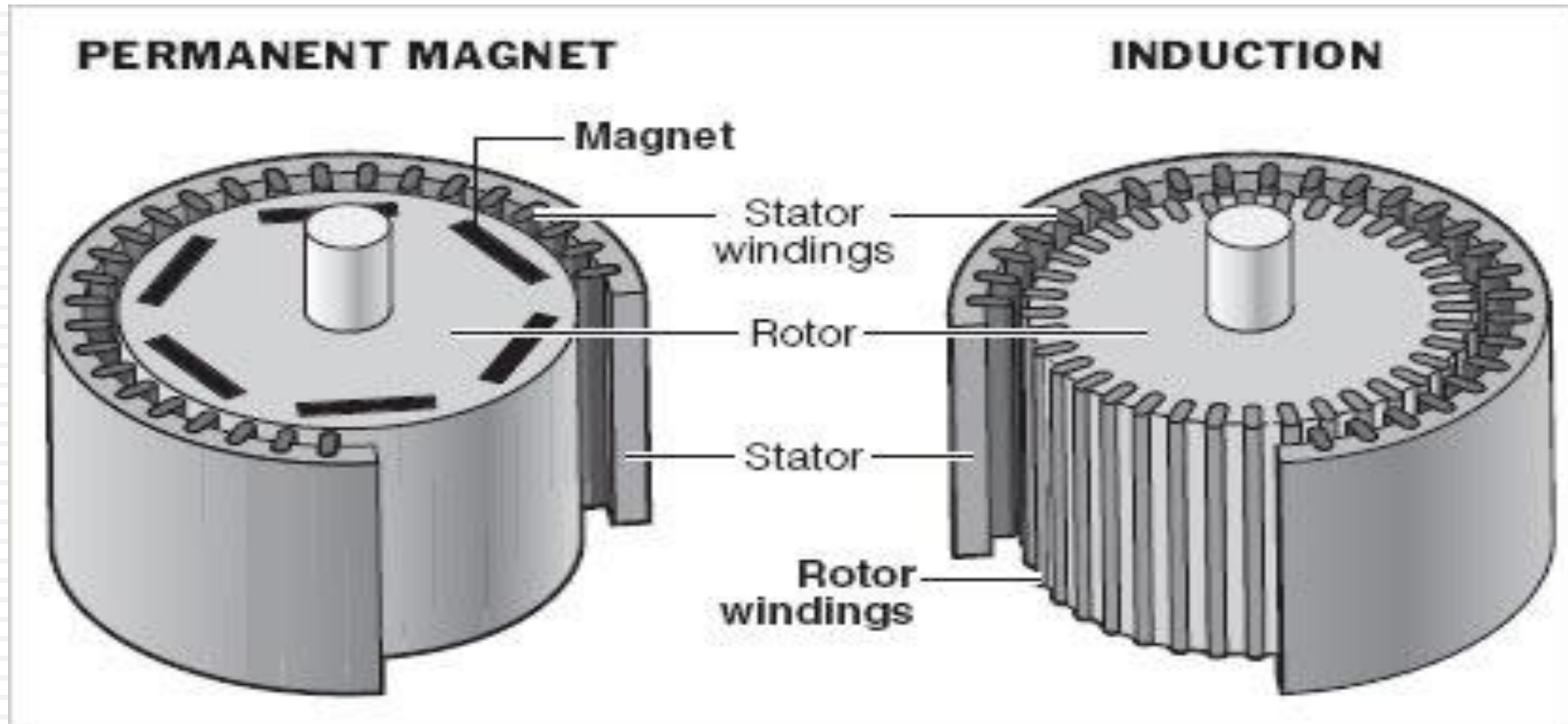

PERMANENT MAGNET SYNCHRONOUS MOTOR

S.No.	Permanent Magnet Synchronous Motors (self starting)					Savings using IE4 PMSM over IE2	
	Frame	kW	Pole	BBL IE4 PMSM Eff %	BBL IE2 Eff %	Energy (kWh) saving/year based on 6000 Hrs running	Rs. Saving/year based on power rate Rs.9 per kWh
1	112M	2.2	4	89.5	84.3	910	8188
2	112M	3.0	4	90.4	85.5	1141	10270
3	112M	3.7	4	90.9	86.3	1302	11716
4	132S	3.7	4	90.9	86.3	1302	11716
5	132S	5.5	4	91.9	87.7	1720	15477
6	132M	7.5	4	92.6	88.7	2137	19230
7	160M	11.0	4	93.3	89.8	2757	24814
8	160L	15.0	4	93.9	90.6	3491	31420
9	180M	18.5	4	94.2	91.2	3876	34885
10	180L	22.0	4	94.5	91.6	4422	39800

Replace Belt driven Fume Extractor with Direct Driven System

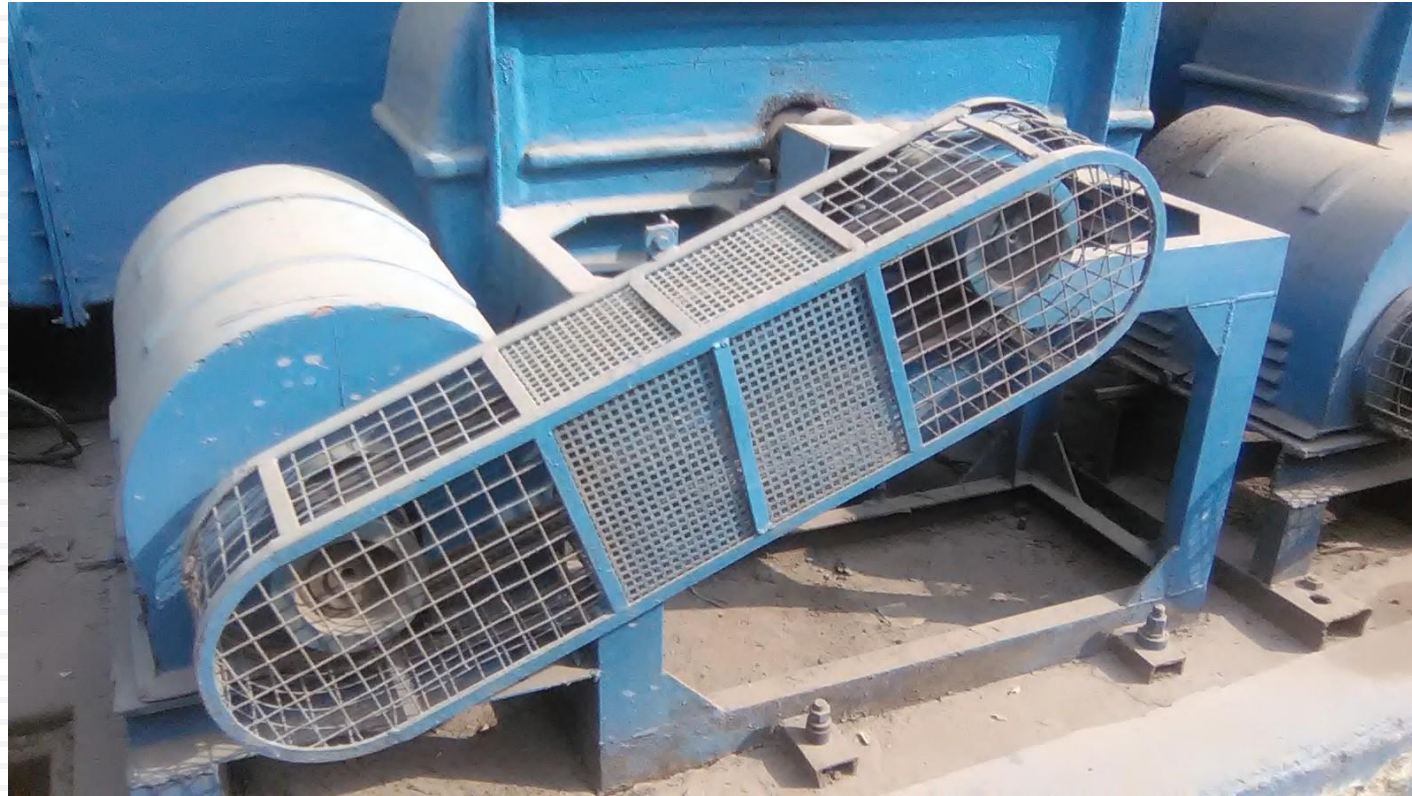

Replace Belt driven Fume Extractor with Direct Driven System

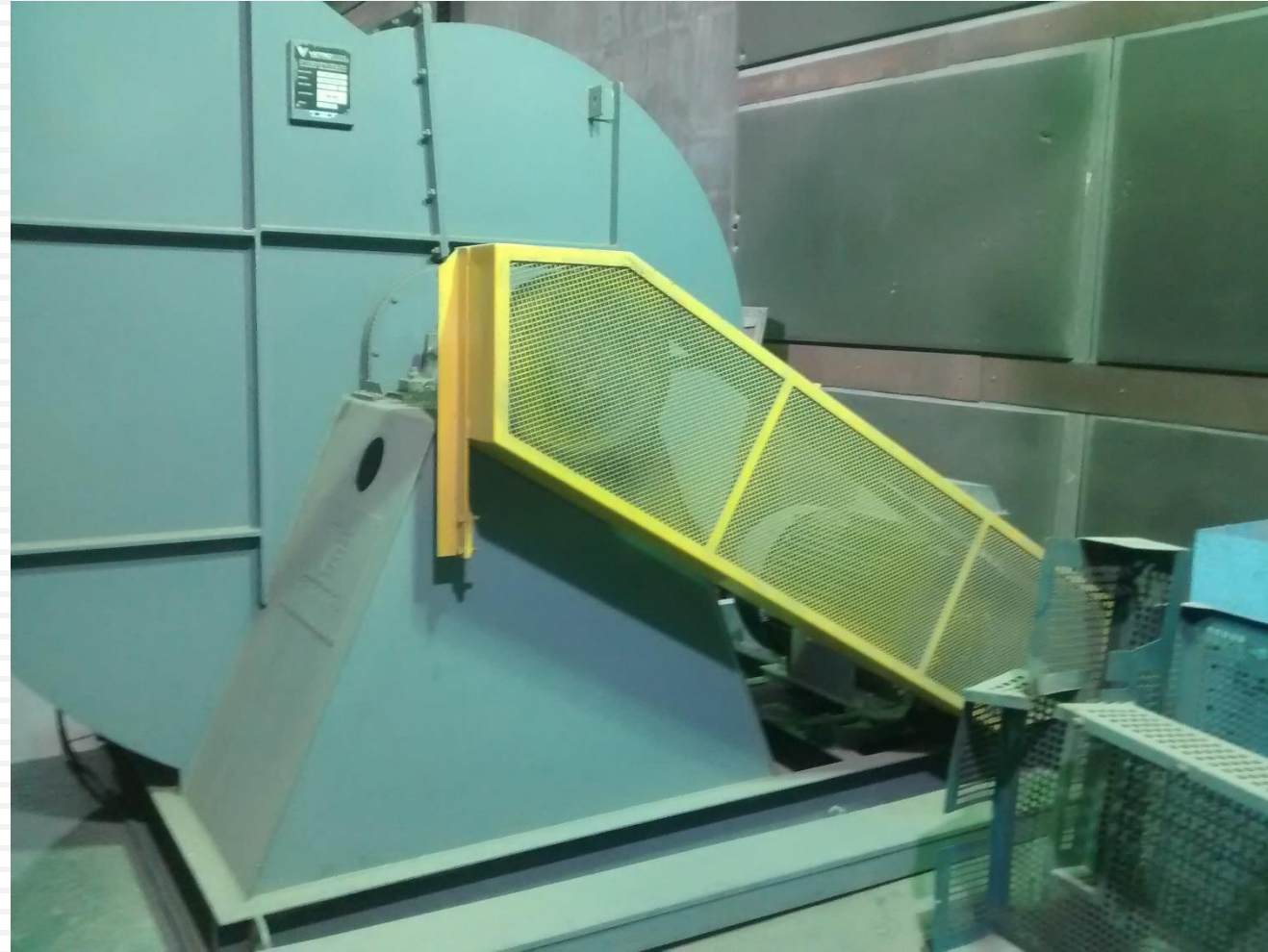

Replace Belt driven Fume Extractor with Direct Driven System

Belt driven mechanism

- Inefficient method
- loss of 7-8% of total operational power
- Motor can be directly coupled to fan to avoid transmission losses



Action Plan

- Couple motor directly with blower
- Save the transmission losses

Replace Belt driven Fume Extractor with Direct Driven System



BLDC in Air Handling Units

System is a combination of all the conventional Motor functions given below

1. Motor
2. FAN
3. Inbuilt VSD
4. Functionality of Starter Panels
5. Voltage and Current Protections.
6. Harmonic Filtration.
7. Power Factor Correction
8. Communication Channels for BMS
9. 30-40 % energy savings

Without Maintenance

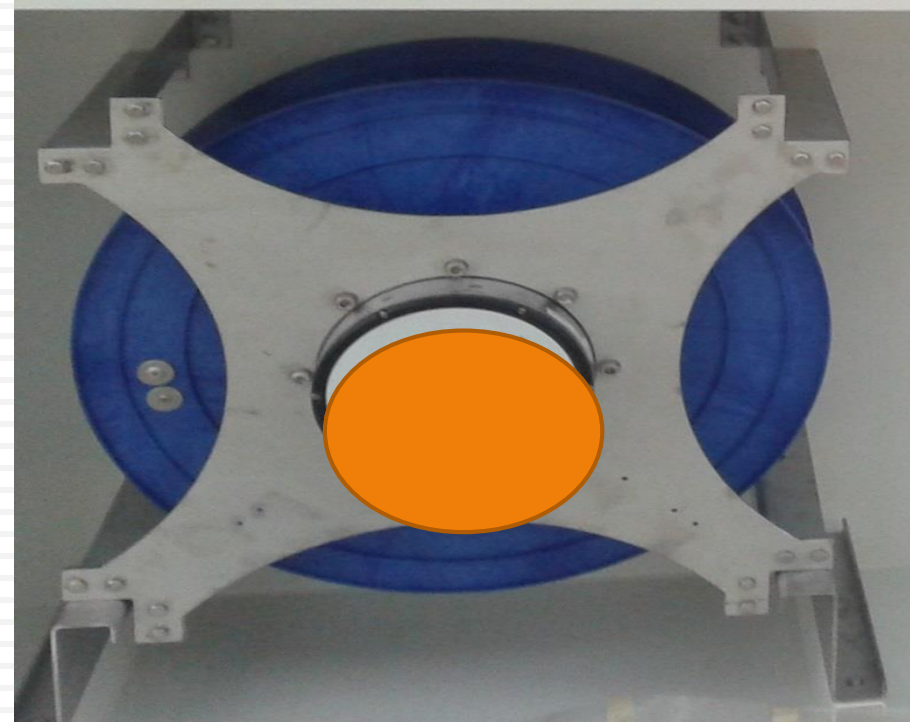

What is the new technology ?

Conventional System



Motion Produced by Slip created in rotor and stator

- ❑ Motor Efficiency at varying load 40-80%
- ❑ Motor Efficiency full load 80 -85%
- ❑ Power Factor at drive level 0.6 to 0.8

Intelligent System

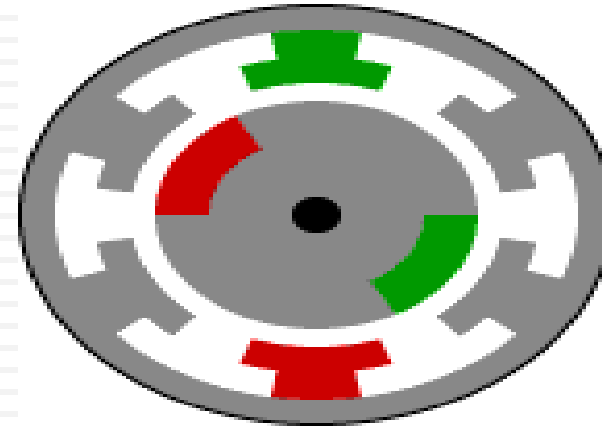

Motion Produced by Opposite Magnetic Field created in rotor and stator

- ❑ Motor Efficiency at varying load 92-95%
- ❑ Motor Efficiency full load >95%
- ❑ Power Factor at drive level Close to unity

Technology Implementation through Retrofit



Technology Implementation through Retrofit



Technology Implementation through Retrofit

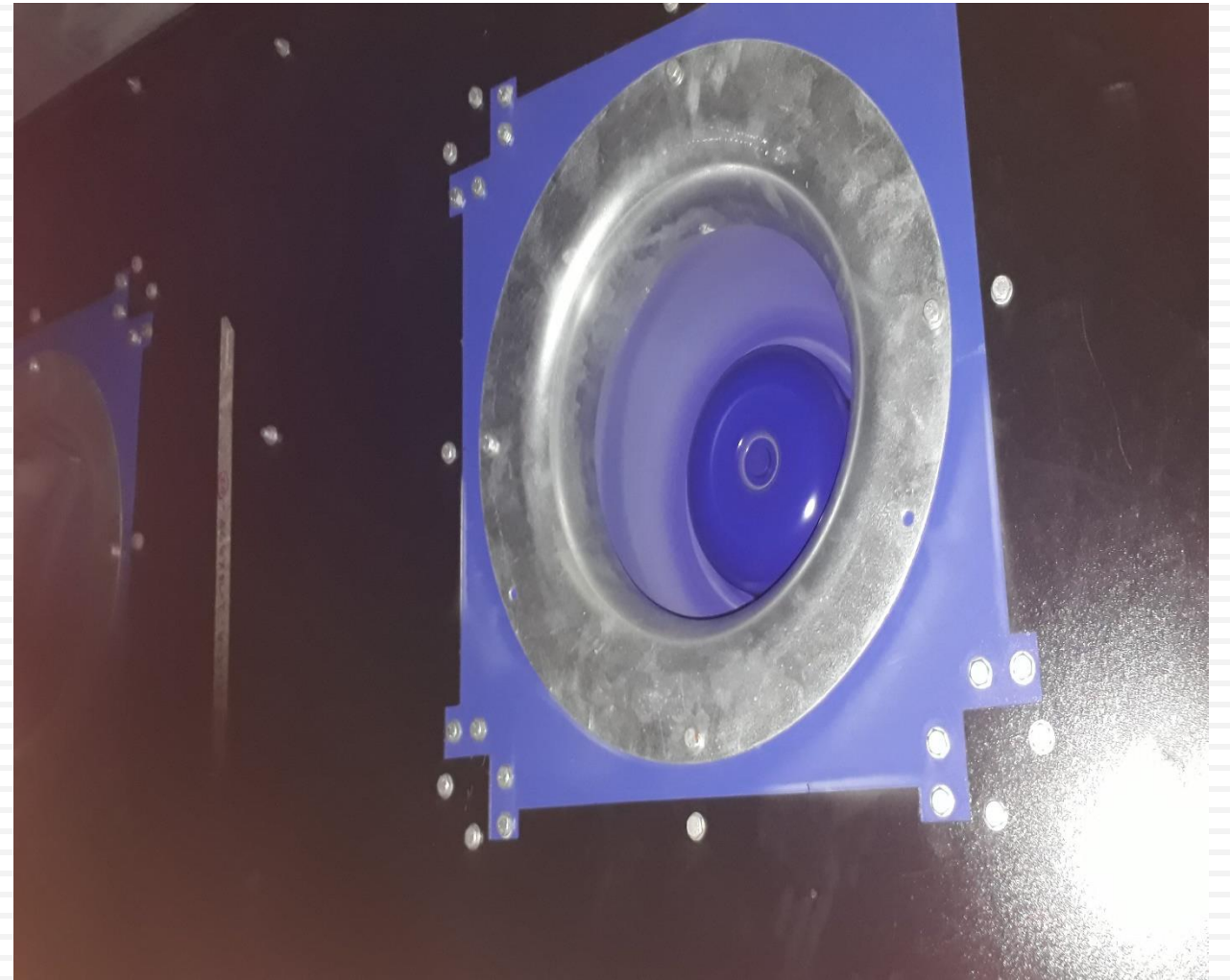

EESL Motor Replacement Program

FEATURES OF PROGRAM:

Motor Efficiency Class: IE3

Ratings Considered (1st Phase):
1.1Kw, 1.5kW, 2.2kw,
3.7kW, 5.5kw, 7.5kw
11kw, 15kw, 22kw

Pole & Mounting:
4 Pole, Foot Mounting

Applications Considered:
Pumps, Blower, Compressor

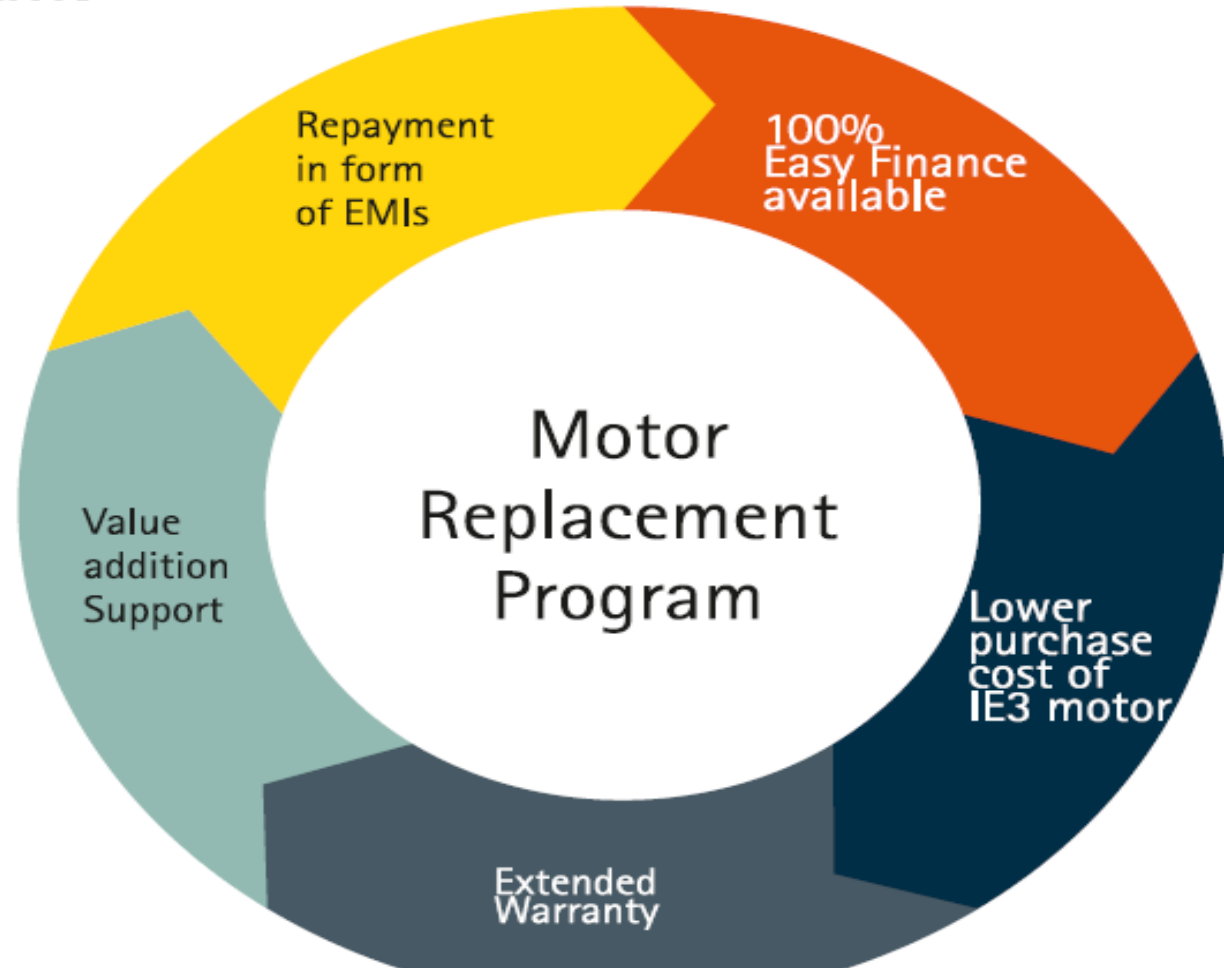

EESL Motor Replacement Program

Cost Benefit Analysis		
Eff. Classification as per IS 12615	IE1 (STANDARD MOTOR)	IE3 (HIGH ENERGY EFFICIENT MOTOR)
Output Kw	2.2	2.2
RPM	1420	1435
Efficiency %	79.7	86.7
% loading	70	70
Utilisation (Hrs)/year	5600	5600
Power Tariff (Rs. Kwh)	7	7
Annual Saving (INR)	-	6115
Approximate price of new motor	6400	8400
Difference in the prices (Rs.)	-	2000
Purchase price recovered in years	-	1.4

Within 16 months of installation, the cost of the entire IE3 motor is recovered (lifetime of a motor is 10-15 years).

Thank You....

